

# Agricultural Biogas Casebook

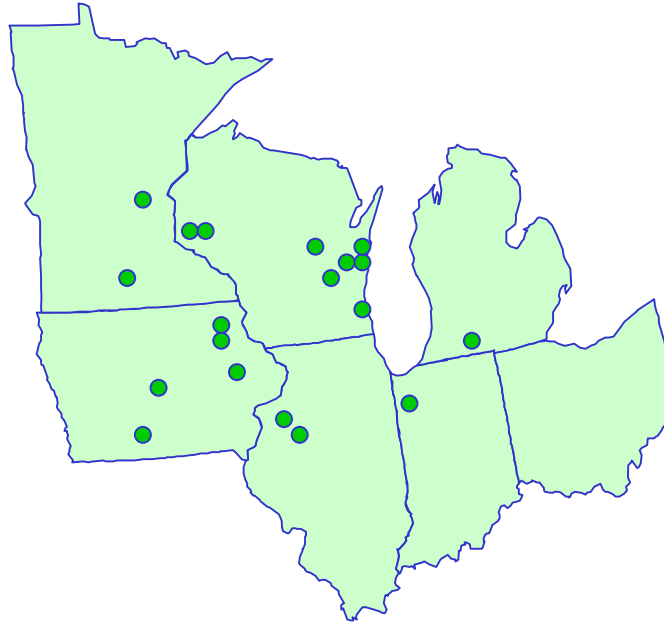

Prepared by:

Joseph M. Kramer

**RESOURCE STRATEGIES, INC.**

September 2002

Prepared for:

Great Lakes Regional Biomass Energy Program  
Council of Great Lakes Governors

## **Table of Contents**

Disclaimer .....	3
Acknowledgements .....	3
abbreviations and definitions .....	4
Chapter 1 - Purpose and Background .....	7
Information Sources .....	8
Methodology and Data Notes .....	9
Report Format .....	9
Chapter 2 - Summary Statistics.....	10
Summary Information .....	11
Some Complaints and Problems .....	17
Chapter 3 - Case Studies .....	19
Summary Table .....	20
Digesters Under Construction.....	21
Herrema Dairy.....	21
New Horizons Dairy .....	22
Northern Plains Dairy .....	23
Digesters in Startup.....	24
Crawford Farm.....	24
Double S Dairy.....	26
Futura Dairy .....	29
Northeast Iowa Community College Dairy Farm .....	31
Stencil Farm .....	33
Tinedale Farms.....	35
Top Deck Holsteins.....	37
Wholesome Dairy.....	39
Operational Digesters.....	41
Apex Pork .....	41
Baldwin and Emerald Dairies .....	43
Fairgrove Farms .....	47
Gordondale Farms.....	50
Haubenschild Farms.....	53
Maple Leaf Farms .....	56
Chapter 4 - Tabular Case Summaries .....	58
Farm Information Subset .....	59
Digester Information Subset .....	60
Digester Outputs Subset.....	62
Cost Information Subset.....	63
Digester History Subset .....	64
Appendix A: References .....	65
Appendix B: Sample of Web-Based Resources.....	67
Appendix C: State Funding Sources or Other Incentives for Agricultural Biogas Projects ....	68
Appendix D: Digester System Designers and Consultants and Equipment Suppliers .....	76

## ***DISCLAIMER***

This report was prepared with the support of the Council of Great Lakes Governors (CGLG) and the U.S. Department of Energy (DOE) Grant Number CGLG-01-014, with assistance from Alliant Energy, Inc. However, any opinions, findings, conclusions or recommendations expressed herein are those of the author and do not necessarily reflect the views of the funders. Neither the author, funders, nor any of their employees, makes any warranty, express or implied, or assumes any legal liability or responsibility for the accuracy, completeness, or usefulness of any information, apparatus, product or process disclosed or represents that its use would not infringe privately owned rights. Reference herein to any specific commercial product, process or service, by trade name, trademark, manufacturer, or otherwise, does not constitute or imply an endorsement or recommendation.

The materials presented in this casebook are, to the best of the author's knowledge, representative of the operations profiled as of June 2002.

## ***ACKNOWLEDGEMENTS***

The author would like to thank the following people for their insights and guidance:

Jim Converse, University of Wisconsin, Madison  
Ray Crammond, AGRIN, LLC  
Steve Dvorak, GHD, Inc.  
Terry Feldmann, Feldmann and Associates  
GLRBEP State Biomass Representatives  
Tim Griswold, Wisconsin Dairy 2020 Initiative  
Duane Hanusa, Alliant Energy, Inc.  
Dick Hauser, Neptune Enterprises  
Bill Johnson, Alliant Energy, Inc.  
John Katers, University of Wisconsin, Green Bay  
Jeff Lorimor, Iowa State University  
Dan Meyer, Iowa State University Extension, Fayette County  
Mark Moser, RCM Digesters, Inc.  
Carl Nelson, The Minnesota Project  
Gepa Porsche, German Biogas Association  
Kurt Roos, EPA AgSTAR Program  
Shihwu Sung, Iowa State University  
Mike Tiry, Tiry Engineering  
Don Wichert, Wisconsin Division of Energy  
Wisconsin Biogas Development Group

And finally, the author would like to thank the owners and operators of livestock operations represented in the case studies who took time out of their busy schedules to share their experiences and make this casebook possible.

Great Lakes Regional Biomass Energy Program, Council of Great Lakes Governors, 35 E. Wacker Avenue, Suite 1850, Chicago, Illinois 60601, USA. Phone: 312-407-0177. Fax 312-407-0038. Web: <http://www.cglg.org>

Resource Strategies, Inc., 22 North Carroll Street, Suite 300, Madison, Wisconsin 53703, USA. Phone: 608-251-2481. Fax: 608-251-5941. Web: <http://www.rs-inc.com>.

## ABBREVIATIONS AND DEFINITIONS

### Abbreviations

AD	anaerobic digestion
ASBR	anaerobic sequencing batch reactor
CHP	combined heat and power
CPI	consumer price index
HRT	hydraulic retention time
RAS	return activated sludge
SRT	solids retention time
TPAD	temperature-phased anaerobic digester
TS	total solids
VS	volatile solids
<b>Units</b>	
AU	animal units
Btu	British thermal units
cf <sub>d</sub> (ft <sup>3</sup> /day)	cubic feet per day
CH <sub>4</sub>	methane
kW	kilowatt
kWh	kilowatt hours
m <sup>3</sup> /kg	cubic meters per kilogram

### Definitions

Acidogenic	acid producing
AgSTAR	a voluntary program jointly sponsored by the USEPA, US Department of Agriculture and the US Department of Energy, that encourages the use of biogas technologies at confined animal feeding operations that manage manures as liquids or slurries ( <a href="http://www.epa.gov/agstar/index.htm">http://www.epa.gov/agstar/index.htm</a> )
Anaerobic Digestion (AD)	the biological, physical and or chemical breakdown of animal manure in the absence of oxygen
Anaerobic Sequencing Batch Reactor (ASBR)	a suspended growth reactor treating waste in four distinct phases over a 12-hour cycle, including digester feeding, digester mixing and gas production, biomass and solids settling, and liquid effluent discharge
Animal Units (AU)	a standardized measure of livestock based on animal weight – for this report it is: dairy cows = 1.4, swine = 0.4, ducks = 0.01
Biogas	the gas produced as a by-product of the anaerobic decomposition of livestock manure consisting of about 60-80 percent methane, 30-40 percent carbon dioxide, and trace amounts of other gases
Combined Heat and Power (CHP)	a system for producing electricity while capturing and using process heat

Combined Phase	digestion phases are in the same vessel
Complete Mix Digester	a controlled temperature, constant volume, mechanically mixed vessel designed to maximize biological treatment, methane production, and odor control as part of a manure management facility with methane recovery
Composting	a process of aerobic biological decomposition characterized by elevated temperatures
Construction Phase	the construction of the digester is not yet complete
Consumer Price Index (CPI)	a standard measure of the value of US currency based on the price of consumer goods in a given year
Covered Lagoon Digester	an anaerobic lagoon fixed with an impermeable, gas- and air-tight cover designed promote decomposition of manure and produce methane
Digestate	the liquid discharge of a manure treatment system
Digested Solids	the solids portion of digested materials
Digester	a vessel or system used for the biological, physical or chemical breakdown of animal manure
Hydraulic Retention Time (HRT)	average length of time any particle (liquid or solid) of manure remains in a manure treatment or storage structure. The HRT is an important design parameter for treatment lagoons, covered lagoon digesters, complete mix digesters, and plug flow digesters
Induction Generator	a generator that will operate in parallel with the utility and cannot stand alone (induction generation derives its phase, frequency and voltage from the utility)
Influent	the materials entering the manure treatment system
Mesophilic	of, relating to, or being at a moderate temperature
Methanogenic	methane producing
Microturbine	energy generation system that involves the direct combustion of gas and electricity generation in a single unit
Net Metering	an agreement with a utility that states the utility will purchase the net energy generated by a distributed generation system
Operational Phase	biogas production is stabilized in the digester
Plug Flow Digester	a constant volume, flow-through, controlled temperature biological treatment unit designed to maximize biological treatment, methane production, and odor control as part of a manure management facility with methane recovery
Psychrophilic	of, relating to, or being at a relatively low temperature
Return Activated Sludge (RAS)	a process by which some of the digester bacteria are returned to the digester reducing the amount of energy the biological system expends on growth of new bacteria

Solids Retention Time (SRT)	average length of time any solid particle manure remains in a manure treatment or storage structure. This is calculated by the quantity of solids maintained in the digester divided by the quantity of solids wasted each day (in complete mix or plug flow digesters $HRT = SRT$ ; in retained biomass reactors, the SRT exceeds the HRT).
Startup Phase	the digester is being fed manure, but biogas production is not yet stabilized
Struvite	a white crystalline substance consisting of magnesium, ammonium, and phosphorus in equal molar concentrations
Synchronous Generator	a generator that can operate either isolated (stand-alone) or in parallel with the utility (i.e., it can run even if utility power is shut down). It requires a more expensive and sophisticated utility intertie to match generator output to utility phase, frequency and voltage.
Temperature-phased Anaerobic Digester (TPAD)	a controlled temperature, constant volume manure treatment system in which the manure treatment process is split into separate phases using different temperature ranges
Thermophilic	of, relating to, or being at a relatively high temperature
Total Solids (TS)	the total amount of solids in manure both in solution and suspension
Two Phase	the digestion phases occur in separate vessels
Volatile Solids (VS)	organic fraction of total solids (TS) (Burke, 2001, estimates dairy manure as excreted to have 10.6% VS by weight)

**CHAPTER 1**  
**PURPOSE AND BACKGROUND**

This casebook presents profiles of farms using anaerobic digesters for animal manures in the Great Lakes States: Illinois, Indiana, Iowa, Michigan, Minnesota, Ohio and Wisconsin. The purpose of this casebook is to provide a picture of the current state of on-farm anaerobic digester (AD) use in these states in the spring of 2002. The summary information provided in these profiles can help those considering using AD technologies to make informed choices and provide a general improvement in implementation efficiency and operator success. Furthermore, through sharing their experiences, these early adopters may help service providers better understand the needs of their customers, and aid the next wave of adopters in making a smooth transition to using biogas systems.

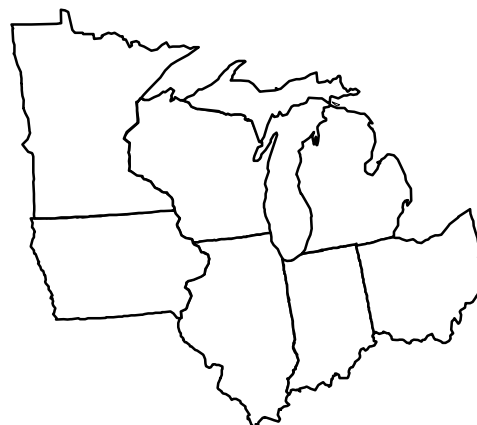

Anaerobic digesters (AD) are manure treatment systems that provide manure handling and environmental benefits to the farm and surrounding area. Digesters also produce several useful by-products that can help reduce operational costs and boost income for the farm. One of these by-products is biogas, a mixture of methane, carbon dioxide and other trace gases. Biogas can be used in a number of ways such as to generate electricity, generate heat, for energy generation with heat recovery (i.e., combined heat and power – CHP), or it can simply be flared.

## Information Sources

A growing body of reference materials exists for those considering use of anaerobic digesters. Interested parties are encouraged to consult these resources. A brief listing of some of these follows, and full references and URLs for specific documents and sites are included in Appendix A.

Foremost among these is the United States Environmental Protection Agency's AgSTAR Program. This program has a freely available handbook (downloadable from <http://www.epa.gov/agstar/library/>) containing technology descriptions, and recommendations for matching systems to specific types of livestock operations. The AgSTAR Handbook also contains (in Appendix F) the U.S. Department of Agriculture Natural Resource Conservation Service Interim Practice Standards that give design and operating parameters for anaerobic digestion systems. Another highly valuable document, *Methane Recovery from Animal Manures: A Current Opportunities Casebook*, was drafted by Lusk (1998), and sponsored by the Department of Energy Renewable Energy Laboratory (downloadable from <http://www.nrel.gov/docs/fy99osti/25145.pdf>). In addition, there have also been several useful state-focused reports written on the feasibility of AD systems. Finally, many of the European Union countries have extensive experience with AD systems (e.g., Germany alone has an estimated 1,650 farm-scale AD systems installed), and have published excellent informational documents.



## **Methodology and Data Notes**

Information gathered for this casebook was provided through interviews with owners or operators of the farms or digesters, designers, engineers, university researchers, and utility personnel who worked with the farms. These interviews were carried out over the period from March 2002 through June 2002. The profiles represent a snapshot of livestock operators' experiences over that period, reflecting projects in various stages of completion or operation.

Due to the limited scope of this project, it was not possible to verify all the data submitted nor to visit each operation and gather the data first hand. The numbers presented in these case profiles are "as-submitted" by the interviewees or "as-presented" in the referenced written sources. In some cases, the farmers themselves were unavailable for interviews. In these situations, designers, utility representatives, other knowledgeable parties and published resources provided the information. Sources of the information for each case are listed at the end of the section. Furthermore, the precision with which operating parameters are measured on each operation varies and in some cases, the measurements are not available. Therefore, comparisons between operations should be done carefully and measures of performance should be recognized as generally approximated figures.

Comparisons between these cases should consider all relevant operational variables. For example, one important variable is the amount of time the digester has been operational. A number for biogas produced in cubic feet per day (cfd) will be much more meaningful if it is calculated over two years than if it was for one month. Whether the measurement is seemingly high or low, a value based on short-term operation may not reflect longer-term performance for that system. In addition, AD systems serve multiple purposes in livestock operations. Therefore, evaluation of a system based on any one benefit will give an incomplete picture of the role the system performs for the farm.

## **Report Format**

This report presents case information in alternative formats to match reader preferences. The first chapter includes the purpose and background for the report, discussion of prominent reference sources, and an overview of the report format. The second chapter of this report contains some summary statistics and tables for the case studies as well as a brief discussion of issues raised by farmers. The third chapter presents the full case studies and the fourth chapter has tabular information from the case studies for easier cross-operational comparisons.

Appendix A lists references and Appendix B lists some Web-based information sources. Appendix C includes descriptions of state funding sources and other incentives for agricultural biogas projects for the Great Lakes States. Appendix D contains a categorized listing of contacts working in and servicing the biogas sector.

**CHAPTER 2**  
**SUMMARY STATISTICS**

## Summary Information

This section provides some summary statistics and cross-case comparisons. These comparisons should be taken for what they are: summaries and calculations often based on estimates and predictions. Calculated figures should be viewed as rough estimates of performance, costs and revenues.

The operational status of the case study farms included in this report is defined as:

<b>Status</b>	<b>Description</b>
construction	not yet complete
startup	digester is being fed manure but biogas production is not yet stabilized
operational	biogas production is stabilized

Case studies of the farms studied that had digesters under construction at the time of the interview have only a limited amount of information, and no operational data. Those in startup phase have more information but still must rely on predictions for performance. Case studies of operational digesters have the most complete information on these systems and can include real experiences with operations.

It should be noted, that even in situations when biogas production is stabilized (i.e., the digester is considered operational), the farm may still be operating with a population below the digester design capacity, or management changes may affect outputs. In these situations, current digester performance might not be representative of normal performance. The case studies themselves should be consulted for details regarding system performance and history.

Two farms with covered lagoons in Wisconsin are included in this casebook but are combined into one case study due to their similarity and the fact that they are owned by the same people. It may be argued that covered lagoons, especially in cooler climates, should be considered as manure storage facilities and not specifically designed for digestion. They are included in this casebook because they produce usable (but currently flared) biogas for a portion of the year and they are considered anaerobic digesters by the AgSTAR program. Profiling these operations will give useful information on lower-end options for manure digestion.

The following table lists the farm names, farm types, digester type categories, state, and status for the farms studied in this casebook.

## Farms in the Great Lakes States with Anaerobic Digesters

Farm Name	Farm Type (Design Population <sup>a</sup> )	Digester Type Category	State	Status <sup>b</sup>
Herrema Dairy (formerly Boss)	dairy (3,750)	plug flow (x2)	IN	construction
New Horizons Dairy (formerly Inwood)	dairy (2,000)	plug flow (x2)	IL	construction
Northern Plains Dairy	dairy (3,000)	plug flow	MN	construction
Crawford Farm	swine finishing (2,800)	ASBR <sup>c</sup>	IA	startup
Double S Dairy	dairy (730)	plug flow	WI	startup
Futura Dairy	dairy (750)	plug flow	IA	startup
Northeast IA CC Farm	dairy (110)	plug flow	IA	startup
Stencil Farm	dairy (1,200)	plug flow	WI	startup
Tinedale Farms	dairy (2,400)	TPAD <sup>d</sup>	WI	startup
Top Deck Holsteins	dairy (700)	plug flow	IA	startup
Wholesome Dairy	dairy (3,000)	plug flow (x2)	WI	startup
Apex Pork	swine finishing (8,300)	complete mix	IL	operational
Baldwin Dairy	dairy (1,100)	covered lagoon	WI	operational
Bell Farms (formerly Swine USA)	swine farrow & gestation (5,000)	complete mix	IA	operational
Emerald Dairy	dairy (1,600)	covered lagoon	WI	operational
Fairgrove Farms	dairy (500)	plug flow	MI	operational
Gordondale Farms	dairy (800)	plug flow	WI	operational
Haubenschild Farms	dairy (900)	plug flow	MN	operational
Maple Leaf Farms	duck (500,000)	complete mix	WI	operational

a. Design population refers to the population that the digester was sized to serve, which is not necessarily the current population of the operation.

b. Status was as of June 2002.

c. Anaerobic sequencing batch reactor

d. Temperature-phased anaerobic digester

Each digester studied is classified by some key characteristics: combined phase or two phase, operating temperature range, basic digester type category, and cover type. The combined phase digesters have both acidogenic and methanogenic digestive phases in the same tank. Two phase digesters separate these phases into different tanks or compartments. Operating temperature ranges are generally classified into three different categories:

- psychrophilic <68°F
- mesophilic 95° to 105°F
- thermophilic 125° to 135°F (Lusk, 1998)<sup>1</sup>

The digester type categories represented by cases in this report are: covered lagoons, complete mix, plug flow, temperature-phased anaerobic digester (TPAD), and anaerobic sequencing batch reactor (ASBR). Finally, digester covers tend to be either fixed (rigid and permanent) or flexible so that they can expand with gas produced.

A summary listing of the digester design details for farms in this casebook is included in the following table.

<sup>1</sup> These defined ranges differ slightly in some European publications. For example, the German Biogas Association defines them as: psychrophilic 10°C (50°F) to 25°C (77°F); mesophilic 30°C (86°F) to 35°C (95°F); and thermophilic 49°C (120°F) to 60°C (140°F) (da Costa Gomez, Claudius, no date).

## Digesters Design Details

<b>Farm Name</b>	<b>Phases</b>	<b>Temperature</b>	<b>Type</b>	<b>Cover</b>
<i>Construction</i>				
Herrema Dairy	combined phase	mesophilic	mixed plug flow loop (x2)	fixed
New Horizons Dairy	combined phase	mesophilic	plug flow (x2)	flexible
Northern Plains Dairy	combined phase	mesophilic	plug flow	flexible
<i>Startup</i>				
Crawford Farm	two phase	mesophilic*	ASBR	flexible
Double S Dairy	combined phase	mesophilic	mixed plug flow loop	fixed
Futura Dairy	combined phase	mesophilic	mixed plug flow loop	fixed
Northeast IA CC Farm	combined phase	mesophilic	plug flow	fixed
Stencil Farm	combined phase	mesophilic	plug flow	flexible
Tinedale Farms	two phase	mesophilic/thermophilic	TPAD	undisclosed
Top Deck Holsteins	combined phase	mesophilic	plug flow	fixed
Wholesome Dairy	combined phase	mesophilic	mixed plug flow (x2)	fixed
<i>Operational</i>				
Apex Pork	combined phase	mesophilic	complete mix (lagoon)	bank-buried floating cover
Baldwin Dairy	combined phase	psychrophilic	covered lagoon	bank-buried floating cover
Bell Farms	combined phase	mesophilic	complete mix	flexible
Emerald Dairy	combined phase	psychrophilic	covered lagoon	bank-buried floating cover
Fairgrove Farms	combined phase	mesophilic	plug flow	fixed
Gordondale Farms	combined phase	mesophilic	mixed plug flow loop	fixed
Haubenschild Farms	combined phase	mesophilic	plug flow	flexible
Maple Leaf Farms	combined phase	mesophilic	complete mix	fixed

\* The operating temperature of the ASBR (86°F) is not considered in the mesophilic temperature range as defined by Lusk, but does fall in that range as defined by the German Biogas Association and that defined by IEA Bioenergy.

As illustrated in the above table, the digesters in this casebook are nearly all combined phase. The combined phase digesters include: plug flow, complete mix, and covered lagoon type reactors. The two-phase digesters are ASBR and TPAD designs. All the plug flow digesters and complete mix digesters are mesophilic, and the ASBR is defined by the designer as mesophilic as well (although its target operating temperature is much lower than the others). The TPAD is the only profiled digester to include a thermophilic phase, with a target temperature of 130°F. The covered lagoons, being unheated, are psychrophilic. The plug flow digesters profiled here (some 14 digesters on 12 farms) represent a considerable variety of designs. These variations include straight versus loop designs, use of biogas mixing, pre-heating of manure, flexible versus fixed tops and use of return activated sludge (RAS).

Biogas generated from AD systems can be used in a number of ways including: electricity generation, heat generation, combined heat and power (CHP), or flare. All farms examined in this casebook using biogas to generate electricity also used the captured heat from the energy generation, at a minimum, to heat the digester itself. Many also used, or planned to use, the captured heat for other applications such as water heat, heating of facilities, and drying solids. Some equipment types and applications used by case study farms are listed in the following table.

## Biogas Applications

Farm Name	Biogas Use	Equipment	Heat Applications	Bedding Type
<i>Construction</i>				
Herrema Dairy	CHP	350kW Hess engine generator (x2)	digester, hot water, biosolids drying	digested solids
New Horizons Dairy	CHP	150kW Caterpillar 3406 engine generator set (x2) (135kW for biogas)	digester, hot water	rice hulls, soybean hulls, want to use some digested solids
Northern Plains Dairy	CHP	160kW Caterpillar 3406T engine generator set (x2) (140kW for biogas)	digester, parlor and floor heat	digested solids
<i>Startup</i>				
Crawford Farm	boiler	undisclosed	digester, hot water, buildings	not applicable
Double S Dairy	CHP	200kW Hess engine generator set	digester, hot water, absorption refrigeration, holding area and freestall barn	want to use digested solids, but now using sawdust/ digested solids mix
Futura Dairy	CHP	140kW Hess engine generator set (synchronous)	digester, hot water	planned digested solids, now rice hulls and composted digested solids
Northeast IA CC Farm	boiler	undisclosed	digester, dairy center, floor heat, hot water	wood shavings
Stencil Farm	CHP	140kW Caterpillar engine generator set	digester, milking parlor, shop and office	digested solids
Tinedale Farms	CHP	375kW Waukesha engine generator set (x2)	digester	digested solids
Top Deck Holsteins	CHP	100kW Waukesha engine generator set, 30kW Capstone microturbine	digester, milking parlors, hot water, floor heat	rice hulls, plan to use digested solids
Wholesome Dairy	CHP	508kW Deutz engine generator set (synchronous)	digester, dairy, manure solids drying	rice hulls and digested solids, eventually all digested solids
<i>Operational</i>				
Apex Pork	boiler	Burnham	digester	not applicable
Baldwin Dairy	flare	not applicable	not applicable	sand (have separation system that drops out 98%)
Bell Farms	CHP	80kW Caterpillar 3306 engine generator set (70kW for biogas)	digester	not applicable
Emerald Dairy	flare	not applicable	not applicable	wood shavings
Fairgrove Farms	CHP	85kW Caterpillar engine generator set (70kW for biogas)	digester	digested solids
Gordondale Farms	CHP	150kW Caterpillar 3406 engine generator set (135kW for biogas),	digester, dairy parlor, holding area, offices, engine room, absorption refrigeration (planned)	digested solids
Haubenschild Farms	CHP	150kW Caterpillar 3406 engine generator set (135kW for biogas)	digester, milking parlor, alleyway, reserve hot water	newspaper (1,700 lbs/day)
Maple Leaf Farms	CHP	200kW Hess engine generator set	digester, offices, lab, utility building	pine shavings

Energy generation equipment was predominantly of the engine generator set type, although some smaller operations used boilers, and one dairy also used a microturbine. All but two of the engines were induction types (i.e. derive their phase, frequency and voltage from the utility).

Several bedding options were used for these dairy operations. The majority of the dairy operations studied either use or plan to use digested solids as bedding for their cows. In some instances, farmers found they needed to further process their digested solids with composting to lower bacteria levels, or mix them with other bedding to lower the moisture levels. Digested solids were sometimes used in combination with rice or soybean hulls or sawdust.

The following table lists some scaled output and cost figures. These numbers should be considered rough estimates of systems' potential. The cost numbers for the "under construction" group are projections. Several of the operational and startup systems had only estimates of costs as well. Installed capacity statistics are based on the amount of electricity the installed equipment could physically generate, and are not scaled to match the farmers' intended operating parameters (e.g., herd size, amount of manure they intend to send to the digester).

## Cost and Installed Capacity Comparisons

Farm	Cubic Feet Biogas per day/Head	Cost/Head at Facility Capacity	Cost/AU <sup>b</sup> at Facility Capacity	KW Installed Capacity	Head per KW	AU <sup>b</sup> per KW	Cost per KW
<i>Construction</i>							
Herrema Dairy	0	not available	not available	700	5.4	7.5	not available
New Horizons Dairy	78	\$500	\$357	270	7.4	10.4	\$3,704
Northern Plains Dairy	50	\$500	\$357	280	10.7	15.0	\$5,357
<i>Startup</i>							
Crawford Farm	15	\$103	\$258	not applicable	not applicable	not applicable	not applicable
Double S Dairy <sup>a</sup>	0	\$500	\$357	200	5.0	7.0	\$2,500
Futura Dairy	0	\$409	\$292	140	5.4	7.5	\$2,193
Northeast IA CC Farm	42	\$1,875	\$1,339	not applicable	not applicable	not applicable	not applicable
Stencil Farm	70	\$333	\$238	140	8.6	12.0	\$2,857
Tinedale Farms	120	not available	not available	750	3.2	4.5	not available
Top Deck Holsteins	74	\$571	\$408	130	5.4	7.5	\$3,077
Wholesome Dairy	0	\$433	\$309	508	5.9	8.3	\$2,559
<i>Operational</i>							
Apex Pork	4	\$18	\$45	not applicable	not applicable	not applicable	not applicable
Baldwin Dairy <sup>c</sup>	0	\$63	\$45	not applicable	not applicable	not applicable	not applicable
Bell Farms	6	\$115	\$288	70	71.4	28.6	\$8,229
Emerald Dairy <sup>c</sup>	0	\$78	\$55	not applicable	not applicable	not applicable	not applicable
Fairgrove Farms <sup>d</sup>	86	\$760	\$542	70	7.1	10.0	\$5,429
Gordondale Farms	0	\$650	\$464	135	5.9	8.3	\$3,852
Haubenschild Farms	78	\$394	\$281	135	6.7	9.3	\$2,630
Maple Leaf Farms <sup>e</sup>	0	\$1.6	\$156	200	2,500.0	25.0	\$3,895

- a. Double S Dairy cost estimates are for the digester only.
- b. Animal Units (AU) are calculated using the following conversion factors (Source Wisconsin Department of Natural Resources), dairy cows = 1.4, swine = 0.4, ducks = 0.01. AU numbers for farms should be viewed as rough approximations of populations.
- c. Baldwin and Emerald Dairy cost figures are for the cover and gas collection equipment alone.
- d. Costs for Fairgrove Farms were converted from 1981 to 2000 dollars using the U.S. CPI inflation multiplier (0.528).
- e. Maple Leaf Farms digester costs are converted from 1988 dollars to 2000 dollars using the U.S. CPI inflation multiplier (0.687). Energy generation equipment was purchased in 2002 and costs were not modified.
- f. Costs and production amounts for systems under construction and in startup are based wholly or partly on estimates and predictions.

The following graph shows the estimated average cost per head by size range for the plug-flow digesters included in this casebook.



## Average Cost per Head for Plug-Flow Digesters by Dairy-farm Size

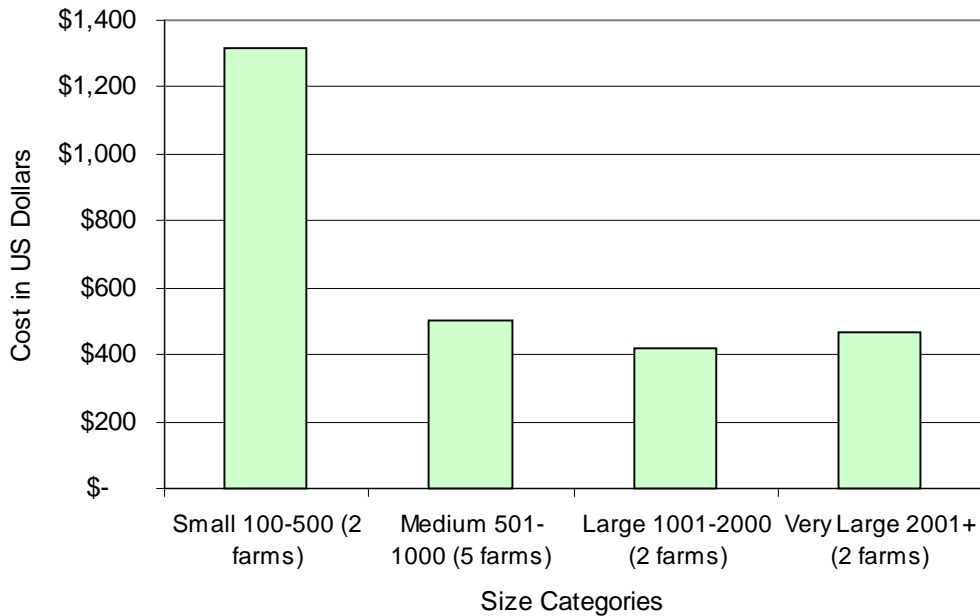

These estimates are based on the design capacity of the installed digesters, not the actual animal population. The digester and energy generation costs for this study for dairy farms with over 500 head averaged between \$400 and \$500 per cow. The two farms in the "small" size category had much higher costs per cow.

### Some Complaints and Problems

Not all of the farmers detailed in this casebook had smooth implementation experiences with their digester or energy generation equipment. A brief look at some of the complaints from and difficulties experienced by these early adopters can help others avoid these problems in the future.

One problem experienced by more than one farm was the production of digested solids that were not suitable for use as bedding. In some cases, use of these solids resulted in mastitis and loss of some animals. These farmers then also had the unexpected costs of arranging for alternative bedding with perhaps uncertain effects on the digester. It appears that more comprehensive information on the conditions that must exist before digested solids can be considered usable might avoid this problem in the future.

Another complaint was that the owners incurred higher than expected costs for propane during startup. In some situations, startup (i.e., the actual heating of the digester to the target operating temperature) took longer than anticipated. These experiences should help developers provide realistic estimations of the needed startup periods so that farmers' expectations are not overly optimistic.

A number of digester owners have experienced problems with their digesters when treating their herds with mineral foot baths. Bacteria populations and biogas production dropped significantly

when the mineral solutions were dumped in with the other residues going into the digester. This most often occurred when the parties managing the foot care and those managing the digester did not communicate. Including as little as one pan of mineral solution in digester inputs can cause a 75 percent drop in biogas production, and require a recovery period thereafter.<sup>2</sup> These treatment baths must be excluded from the digester inputs and disposed of elsewhere.

Finally, some operations have had difficulty with operational digesters when the farm was sold or when they went through a management change. In these situations, the new owners or managers must go through a learning period or seek outside help to understand the requirements for care and maintenance of the anaerobic digester and energy generation equipment.

Successful implementation of an AD system often requires major changes in operation and management of the farm. Some systems are installed with the intention of accommodating lesser changes, but the most successful implementations are when the farm makes all necessary adjustments so its practices are consistent with good digester operation. Dennis Haubenschild of Haubenschild Farms said that to be successful, use of a digester "...has to be part of an overall plan for managing manure." Kyle Gordon of Gordondale Farms suggested that the farm must agree to make "...all necessary changes in operation" such as switching from sand bedding and using water conservation measures "...so that the system will work right." David Pueschel of Fairgrove Farms said "You have to think of the digester as a big stomach that needs to be fed twice a day." These three are examples of farmers who made significant changes to their operations and have successful AD systems.

---

<sup>2</sup> Bill Johnson, Alliant Energy, Inc., personal communication, June 2002.

**CHAPTER 3**  
**CASE STUDIES**

## Summary Table

The following tables list the case studies included in this casebook sorted by their stage of development. The case studies are included in their entirety in this section.

### Digesters Under Construction

Farm Name	Digester Type	Farm Type	State	Projected Startup Date	Designer
Herrema Dairy	plug flow (x2)	dairy	IN	August 2002	GHD, Inc.
New Horizons Dairy	plug flow (x2)	dairy	IL	August 2002	RCM Digesters, Inc.
Northern Plains Dairy	plug flow	dairy	MN	November 2002	RCM Digesters, Inc.

### Digesters in Startup

Farm Name	Digester Type	Farm Type	State	Startup Date	Designer
Crawford Farm	ASBR	swine finishing	IA	first May 1999, second June 2002	Shih Wu Sung and Fox Engineering
Double S Dairy	plug flow	dairy	WI	March 2002	GHD, Inc.
Futura Dairy	plug flow	dairy	IA	March 2002	GHD, Inc.
Northeast IA CC Farm	plug flow	dairy	IA	first April 2001, second May 2002	IA County Extension
Stencil Farm	plug flow	dairy	WI	January 2002	RCM Digesters, Inc.
Tinedale Farms	TPAD	dairy	WI	first June 2001, second 2002	Ag Environmental Solutions
Top Deck Holsteins	plug flow	dairy	IA	first January 2002, second May 2002	IA County Extension, AGRIN, LLP
Wholesome Dairy	plug flow (x2)	dairy	WI	April 2002	GHD, Inc., Tiry Engineering did concrete

### Operational Digesters

Farm Name	Digester Type	Farm Type	State	Date Operational	Designer
Apex Pork	complete mix	swine finishing	IL	June 1998, January 1999	RCM Digesters, Inc.
Baldwin Dairy	covered lagoon	dairy	WI	1998	Tiry Engineering
Bell Farms	complete mix	swine farrow and gestation	IA	September 1999	RCM Digesters, Inc.
Emerald Dairy	covered lagoon	dairy	WI	1999	Tiry Engineering
Fairgrove Farms	plug flow	dairy	MI	January 1981	AGRIN LLC, Perennial Energy
Gordondale Farms	plug flow	dairy	WI	April 2002	GHD, Inc.
Haubenschild Farms	plug flow	dairy	MN	September 1999	RCM Digesters, Inc.
Maple Leaf Farms	complete mix	duck	WI	1988	Applied Technologies, Inc.

## Digesters Under Construction

### *Herrema Dairy*

*combined phase, mesophilic, plug-flow loop gas mixing, fixed cover*

Herrema Dairy (formerly Boss Dairy) is a new dairy being built in Fair Oaks, Indiana, which began construction in March 2002. The dairy and digester are being built at the same time. They plan to gradually populate it with between 3,500 and 4,000 cows.

Digester. They are installing two mixed, heated, plug-flow loop digesters, side-by-side. The target operating temperature is 100°F. They plan to use pumped-in biogas to do the mixing and return activated sludge (RAS) into the digesters. They expect to feed between 115,000 and 132,000 gpd of manure to the digesters at a solids content of about ten percent. The digesters' status as of May 2002 was under construction. GHD, Inc. designed these digesters.

Biogas Use. The biogas will fuel two Hess 350kW engine generator sets, and they expect to consistently produce between 500 and 600 kW total. Waste heat will be used for the digester, hot water, and to help dry the manure solids.

Revenues/Savings. Estimates of revenues or savings for this system were not available.

Cost Estimates. Cost projections for this system were not available.

Information Sources. Derrick Herrema, Herrema Dairy  
Steve Dvorak, GHD, Inc.



### ***New Horizons Dairy***

*combined phase, mesophilic, plug-flow, flexible cover*

New Horizons Dairy (formerly Inwood Dairy) of Elmwood, Illinois, is a new dairy that began construction in May 2002. The dairy and digester are being built at the same time. The farm is expected to house 2,000 head by September 2002.



Digester. The owners chose to install two heated plug-flow digesters for manure management. The digesters will share a heated wall, be mostly buried and use flexible covers. They expect to input 40,000 gallons of manure per day at a solids content of about 13 percent, and produce between 140,000 and 170,000 cubic feet per day of biogas. The digesters' status as of May 2002 was under construction. RCM Digesters, Inc. designed these digesters.

Biogas Use. This biogas will fuel 2 Caterpillar 3406 naturally aspirated engine generator sets rated at 150kW each (135kW for biogas). They also plan to use waste heat for digester heating and for hot water.

Revenues/Savings. Predicted annual savings include \$7,000 in propane replacement (at an assumed price of \$0.75/gal), \$110,000 replacement of farm electricity purchases, \$6,000 in sales of excess electricity, \$64,000 in digested solids sales and methane credits totaling \$16,000 (at \$1.50/ton CO<sub>2</sub> equivalent). Total gross revenue and savings are predicted to be approximately \$203,000. Other costs associated with annual operation and maintenance are not currently available.

Cost Estimates. The projected cost for this system (digester and energy generation) is approximately \$1 million. A grant from the Illinois Department of Commerce and Community Affairs Renewable Energy Resources Program for \$339,060 was used to help fund this project.

Information Sources. Jeff Trapp, Inwood Dairy  
Mark Moser, RCM Digesters, Inc.  
Terry Feldmann, Feldmann & Associates

### ***Northern Plains Dairy***

*combined phase, mesophilic, plug-flow, flexible cover*

Northern Plains Dairy is a new dairy being built in St. Peter, Minnesota, which began construction in May 2002. The dairy and digester are being built at the same time. They plan to populate the dairy with 3,000 Jersey cows.

Digester. The owners are installing a heated plug-flow digester with a flexible top. They expect to feed the digester around 60,000 gpd of manure at a solids content of about 13 percent. As of May 2002, the digester was under construction. RCM Digesters, Inc. designed this digester.



Biogas Use. The biogas will fuel two Caterpillar 3406T engine generator sets rated at 160kW (~140kW for biogas). They expect to consistently produce 280kW of electricity. Heat from the engines will be used to heat the digester and for parlor and floor heat.

Revenues/Savings. Estimates of revenues or savings from the system were not available.

Cost Estimates. The projected cost for this system is about \$1,500,000.

Information Sources. Mark Moser, RCM Digesters, Inc.

## Digesters in Startup

### Crawford Farm

*two phase, mesophilic, ASBR, flexible cover*

Crawford Farm is a swine finishing operation in Nevada, Iowa. They have a capacity for a herd size of 3,000 but tend to operate at around 2,800 head, managed all-in, all-out. This herd generates just under 15,000 gpd of manure that is combined with an equivalent amount of process water resulting in a loading to the digester of about 29,000 gpd. Manure falls through the slatted floor of the confinement facilities into a shallow pool of recycled water (digestate). This treated water is used to carry the solids and make them pumpable. Manure is collected using a pull plug and a scraper system. The raw manure as fed into the digester with the recycled water has been sampled at about two percent solids.

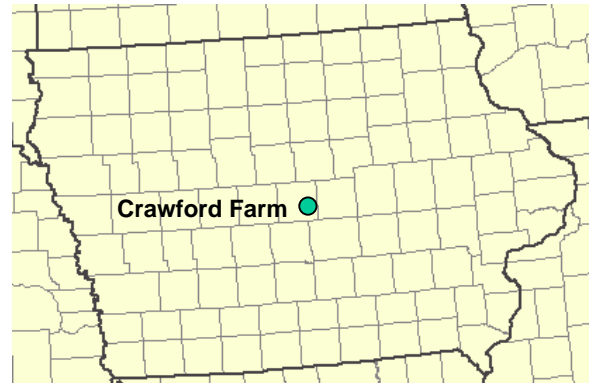

Digester. Dr. Shih Wu Sung of Iowa State University and Fox Engineering have designed an anaerobic sequencing batch reactor (ASBR) to digest the manure. Manure is batch fed and batch decanted within the digester, which differentiates it from other ASBR systems. An inflatable cover on the 50 foot diameter cylindrical tank collects the biogas. The figure below is a flow diagram of the system.

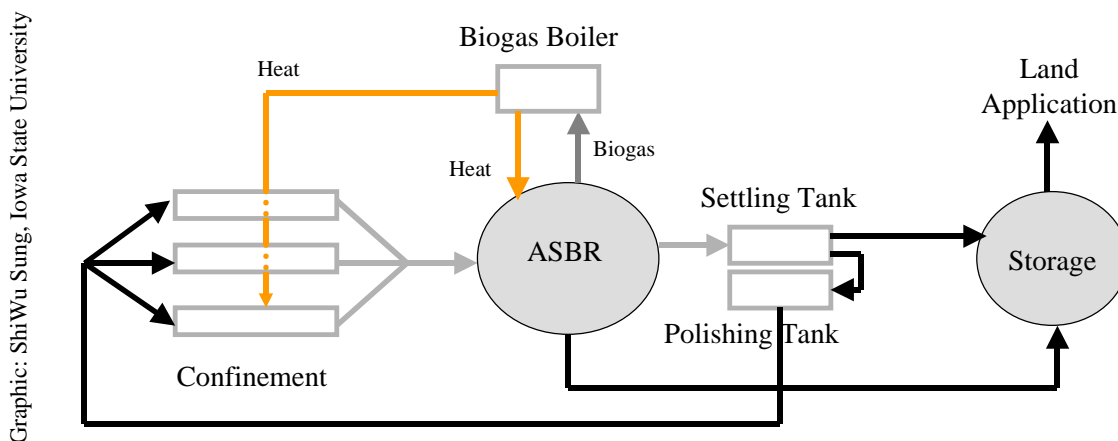

The digester volume is about 165,000 gallons, and it is designed for a hydraulic residence time (HRT) of about 15 days. Each batch flows into the 25,000 gallon settling tank after the digester, where for 30 minutes the heavier solids settle out. Then the upper, somewhat clarified, portion of the batch is sent to a polishing tank for a 15-minute aeration to strip off the ammonia and correct the pH. The digestate is then fed back to the under-floor of the confinement area to be re-used as a medium for the raw manure. Because the liquid digestate is added to the system along with raw manure, this provides some bacteria recycling. The bottom portion of the batch in the settling tank is then stored in a lagoon until it can be land-applied.

The ASBR is designed to operate in the mesophilic range, at a temperature of at least 81° F or 27° C, with an optimum temperature of about 86° F or 30° C.



Outputs and Uses. When running in steady state (in the Summer 1999) the digester was producing between 40,000 and 45,000 cfd of biogas with a methane content of about 74 percent. The biogas from the digester fuels a biogas boiler that provides heat for the digester, and will also heat water and some buildings. When biogas builds up excess pressure, it is flared until an acceptable pressure level is reached.

Maintenance Needs. The digester, as of May 2002, requires a minimum of 1.5 person-hours per day to operate. The scraper system is not automated, and therefore requires manual operation. Long-term maintenance needs are not known.

Project History. They have had numerous problems. They had difficulty finding suitable experienced contractors in a timely manner. They experimented with different loading levels, and overfed it initially. They ordered a pre-cast concrete tank, which was not originally designed for this purpose, with an inflatable top. Pressure from snow and wind caused the tank wall to crack in winter 1999. They then poured a concrete ring around the new wall, and buried and bermed it up to give it more support. They also experienced a lightning strike that fried the control panel and the replacement panel failed to operate correctly. They also lost a transformer during a brownout. Because of these electrical problems, they need to run the digester manually when it was designed to be automated. As of May 2002, they were no longer feeding the digester and were awaiting a part.

System Costs. The estimated total cost for this system was \$290,000. They had predicted the costs to be about \$215,500, but experienced unexpected costs of around \$79,500. They also received \$30,000 from the Iowa DNR for research of the ASBR system (not included in the total cost figure). During the winter of 1998-99, they also had to spend around \$4,000 on propane (at \$0.83/gal propane) costs to heat the digester up to a temperature where methanogenic activity could occur. This will likely be lower in the next startup in summer 2002. They have seen an increase in their electric bill of about \$240 per month to run the pumps and agitators for the digester.

Revenues and Other Benefits. The digester system has greatly reduced odor from the storage tank and since they inject the manure, the odor for neighbors is also reduced. They took odor measurements using a dilution test and found a 78.5 percent reduction in odor from raw manure to digestate. The owner also expects to produce propylene glycol and offset some water heating costs. Dollar amounts of revenues or savings are not available.

Lessons and Comments. The owner said that if they do another digester like this, they need to make it more self-sufficient. The system, as set up now, requires too much time and effort to operate. He also felt that simplifying the system would make it easier to work with. The owner and designer/researcher both stressed the importance of hiring contractors who have experience in this area.

Information Source. Steve Crawford, Crawford Farms  
Shih Wu Sung, Iowa State University

## Double S Dairy

*combined phase, mesophilic, plug-flow loop gas mixing, fixed cover*

Double S Dairy is a dairy operation in Markesan, Wisconsin. As of May 2002, they were milking approximately 700 cows, and had about 730 total feeding the digester. They are planning to expand to about 1,000 cows and have chosen a digester size based on that number. They had an existing dairy, and have recently expanded adding a second larger barn. They use flush collection and recycle the water before the digester. They had been using sand bedding, but when they decided to add a digester, they switched to three quarters digested solids with one quarter sawdust to make it drier. They expect to load nearly 30 gpd manure per cow for a current load of about 21,000 gpd (and up to 30,000 gpd when at 1,000 cows). They use a screw press for solids separation post digestion. The solids percentage in the influent was not known.



Digester. GHD, Inc. designed a heated, mixed, plug-flow loop digester for the farm. The digester has a fixed cover, and combines the digestion phases within the loop including settling. The figure below shows a general design for a plug-flow loop digester.

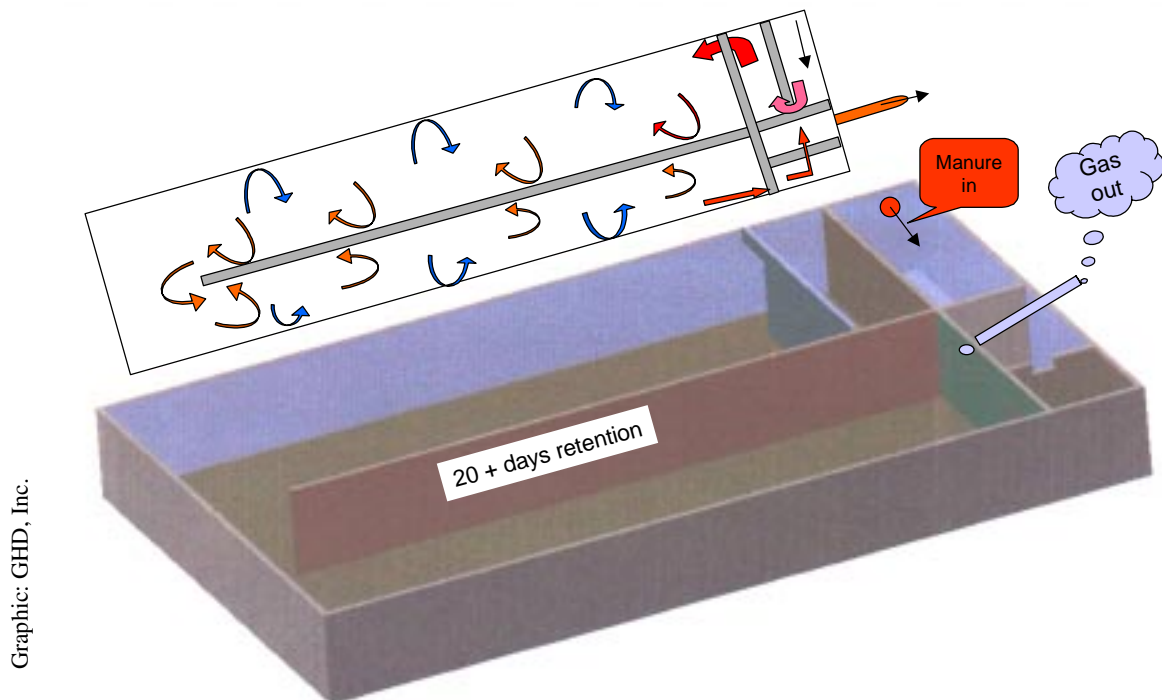

Graphic: GHD, Inc.

The system is designed for a HRT of about 20 days. This system returns activated sludge (RAS) into the digester, recycling some bacteria. The solids retention time (SRT) is estimated to be 25-30 days. It also feeds biogas back into the plug at the bottom to provide some non-mechanical mixing as the gas rises through the plug. The target operating temperature is 100°F.

The total digester volume is about 600,000 gallons. Its dimensions are approximately 60 feet by 107 feet by 14 feet.

### Outputs and Uses.

Predicted biogas outputs were not available. The biogas will fuel a Hess 200kW induction engine generator set (pictured at right). Alliant Energy owns the generation equipment. They predict that the system will produce between 1.2 and 1.6 million kWh of electricity per year. They will also use recovered heat for the digester, water heating, absorption refrigeration system, holding area and the freestall barn. They hope to use digested solids for bedding, but have not yet been able to do so.

Photo: Alliant Energy, Inc.



Maintenance Needs. The maintenance needs of this system were not yet known.

Project History. The digester was built at the same time as the dairy addition: between October 2001 and February 2002. They started feeding the digester manure in March 2002 and were able to start running the engine on biogas in May 2002. As of May 2002 they were still in startup mode (i.e., biogas production had not yet stabilized).

They have had problems on a number of fronts and feel disorganization and lack of communication among the parties involved was significant. First, they completed the digester but the cover had not been ordered yet, causing a delay in the startup. They switched from sand bedding when the digester was installed, and had been counting on use of solids to help defray digester costs. Because of the delay in startup, they had to buy bedding until solids were produced, incurring higher than expected costs for bedding. The first batches of solids used had high bacteria counts and caused mastitis resulting in the loss of some cows. As of June 2002, they were still not getting the predicted amounts of solids. They have been paying for propane also to heat the digester for some time. In addition, they experienced some engine/generator failures each requiring a replacement part and a wait for the order. Biogas production has risen recently now that they are approaching their target operating temperature. As of June 2002, they were running the generator at a steady 160 kW, at an operating temperature of about 90° F and still climbing.

As of June 2002, they did not yet have a utility contract but expected to agree to terms with Alliant Energy in which they sell the biogas to the utility based on measurements from gas meters on both the engine and the flare.

System Costs. The costs associated with the digester are estimated to approach \$500,000 (they have not all been incurred or tallied yet). The project was originally budgeted to be about \$391,000. Some of the unexpected costs, include: bedding, propane and animal loss due to mastitis. Costs associated with the energy generation portions of the system, which are owned by the utility, were not available. Many of their costs such as delays in their operations and increased management attention needed are not easily quantifiable. Routine operation and maintenance costs were not yet available.

Revenues and Other Benefits. Revenues and other benefits were not yet known. They predict that at 1,000 cows they will be able to produce between 1.2 and 1.6 million kWh per year. They hope to save on bedding costs by using digested solids, but are not yet sure what that amount will be.

Lessons and Comments. The owners are not sure at this point whether they would recommend this type of system to colleagues. They still have not seen it fully operational, and the delays have caused them much inconvenience and expense.

Information Sources. Dan Smits, Double S Dairy  
Steve Dvorak, GHD, Inc.  
Duane Hanusa, Alliant Energy

## *Futura Dairy*

*combined phase, mesophilic, plug-flow loop gas mixing, fixed cover*

Futura Dairy is a dairy operation in Central City, Iowa. They had 420 cows (their current capacity) as of June, 2002, with plans to possibly expand to 1,100 at some time in the future. They use a scrape method of manure collection. They use rice hulls and composted digested solids for bedding. They were feeding approximately 8,000 gallons of manure per day into the digester (4,000 twice per day). They use a Vincent screw press separator to separate out solids post digestion. The owners were uncertain what the percent solids was in the influent.

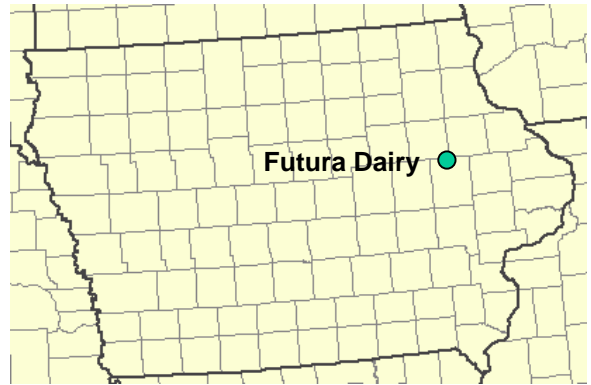

Digester. Designed by GHD, Inc., the Futura Farm digester is a mixed, heated, plug-flow loop design in which the biogas is fed back into the digester at the bottom to provide some non-mechanical mixing (see the schematic in the Double S Dairy profile). The digester has a fixed cover and RAS. Its approximate dimensions are 56'W x 60'L x 14'D. It combines three phases within the loop, acidogenic, methanogenic and settling. Capacity is about 30 days of production, and digester volume is about 150,000 gallons. The design HRT is 20 days, but it is currently about 25-30 days because of the smaller animal population. The target operating temperature is 100°F.

Outputs and Uses. The amount of biogas being produced as of June 2002 was not known because no gas meter was installed. The intended use for the biogas is to fire a Hess 140 kW synchronous engine generator set (operates independently of the electric utility system). They also plan to capture an unknown amount of waste heat and use it to heat the digester and water.

The owners intended to use digested solids for bedding, but as of June 2002 were composting digested solids and using some for bedding and selling some as compost for landscaping.

Maintenance Needs. No maintenance history is yet available.

Project History. The digester was built while the new dairy was being built from April 2001 to September 2001. They started adding manure in September 2001 but have been operating with a smaller animal population than anticipated. They have had some problems. A leaking tank needed re-sealing and they then found other leaks as well. Their separator has needed several screens replaced. The biosolids they are producing have had high moisture and bacteria counts and some cows got sick. They had to add composting and use a mix of rice hulls and composted digested solids for bedding which was not a planned expense. They have had problems getting the biogas recirculation system (for mixing of the plug) to work.

They are not connected to a utility and have had numerous problems with the generator. The generator problems were related to fluctuating load (the first time they tried it the engine ran out of biogas in 20 minutes – since then they have had it run up to about 35 minutes before running out of gas). They have not yet been able to run the engine consistently because they are not

producing enough biogas. They ordered a special carburetor to allow them to burn a mixture of biogas and LP gas, but as of June 2002, it was still not functional. They think they would probably work with a utility next time to simplify some things.

As of June 2002, the system had not yet stabilized and they were problem solving.

System Costs. The total costs to get the system operational are not certain (it is still in startup mode). Estimated cost of the digester and supporting equipment is about \$132,000 (the same company that built the dairy built the digester). The energy generation equipment (including the synchronous generator and a backup generator) cost about \$163,000. They experienced unexpected costs which included having to buy a year's worth of propane at a cost of about \$40,000, and bedding costs are about \$8,000 per month. They also had to replace all the pumps and several torn separator screens, as well as add composting.

Revenues and Other Benefits. Revenues and other benefits were not yet available.

Lessons and Comments. The owners feel the concept of anaerobic digestion is "great" but they have not yet seen the benefits. They think there is a lot of new technology involved and are not sure whether they are doing something wrong or what is causing their problems. They feel they were not given enough information on what was needed to properly run the digester, and feel ill equipped to address the problems they are having. They have continued to put money and effort into the system but have yet to see any return.

They would probably choose to work with a utility and use an induction generator if they were to do it again. They have found that their energy demands for the farm are higher than they anticipated and they overestimated the efficiency of the generator.

Information Sources. Steve Covington, Futura Dairy  
Mike Gregorika, Futura Dairy  
Steve Dvorak, GHD, Inc.

### Northeast Iowa Community College Dairy Farm

*combined phase, mesophilic, plug-flow, fixed cover*

The Northeast Iowa Community College Dairy Farm is an applied research facility located in Calmar, Iowa. The dairy farm has a total population of 170 cows with about 155 milking. However, only about 100-120 cows feed the digester (50-60 cows are housed at different location). They are currently producing an estimated 40 gallons per cow per day in influent. They are considering diverting the parlor wash water to drop this amount to about 26 gallons per cow per day. These two options amount to about 4,400 gpd or 2,860 gpd fed to the digester under each practice. They are using wood shavings for bedding and the overall solids content of the influent is unknown. They installed a Vincent screw press solids separator before the digester. Separated solids are sent to a separate storage building where they are composted with an under-floor forced air assist system.

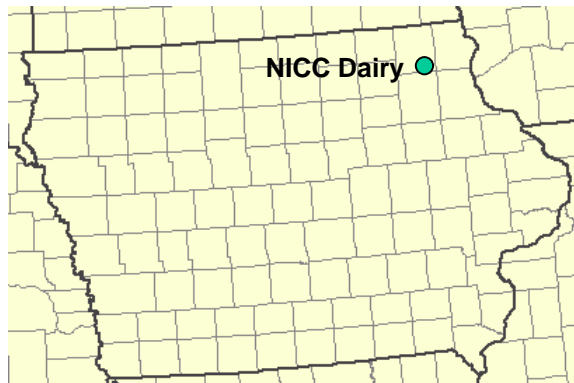

**Digester.** The digester, designed by Dan Meyer of the Iowa State University Agricultural Extension, is a poured concrete, heated plug-flow type with a fixed cover. The figure on the right is a rough diagram and flow chart of the digester and other structures.<sup>3</sup> The digester target temperature is 98°, and should have a 13-14 day HRT if parlor wash water is included. The digester has the capability of using RAS but they don't know yet if they will use it in that way.

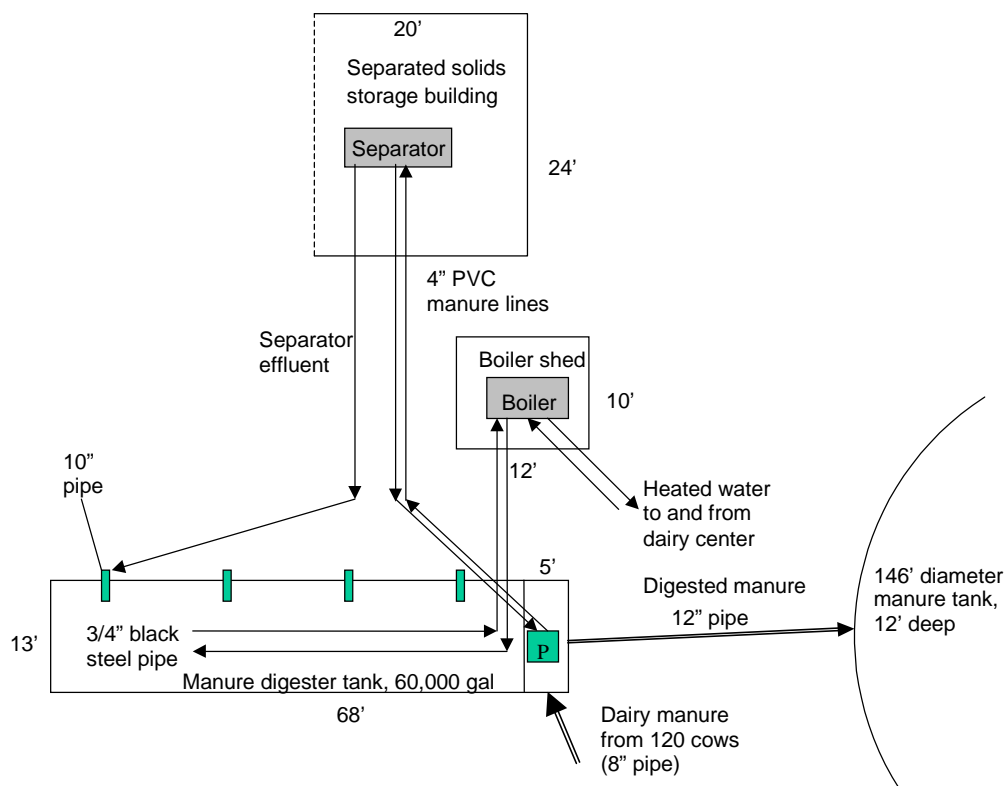

The overall volume of the digester is 60,000 gallons. The approximate size of the digester is 13'W x 68'L x 10'D.

**Biogas Use and Other Outputs.** During the first startup they were briefly producing 42 f<sup>3</sup> per cow per day of biogas, but expect that to be lower because of the solids removal before the digester. The biogas produced will fire a 150,000 Btu/hr rated boiler, with expected output of about 120,000 Btu/hr with biogas. They have two exhaust chimneys. The heat from the boiler

<sup>3</sup> This figure is adapted from information provided by Dan Meyer, ISU Agricultural Extension. It is not drawn to scale.

will be used for the digester first, then dairy center, floor heat and hot water. They need 6,200 ft<sup>2</sup> of floor heat. Solids are field applied unless composting is used.

Maintenance Needs. They had to clean out the digester once because of a large mat of solids at the top. Routine maintenance information was not yet available.

Project History. It was built over the period from August 2000 through October 2000, and a boiler was added in March 2001. The first startup period was April 2001 and a second startup was in May 2002. As of June 2002, the system was still in startup mode.

When they first started feeding the digester they had the solids separation after the digester. They soon developed problems with the solids floating to the top in the digester to form a crust. The plug then did not flow properly and they needed to clean it out. They then switched the separator to before the digester and started composting the solids in a separate building with underfloor forced air assist. They also had a problem with freezing in the initial plumbing setup, which was not buried deep enough, and had some 90° corners that impeded flow. They now think the pipes should be greater than 1 foot below the ground if buried. The plumbing was moved to be above ground and is gravity flow. The solids separator screen broke after three days of use. Then they had plug blowouts due to solids problems. As of June 2002 they were filling the tank again but the solids separator was still not working.

System Costs. The cost for the digester and system at last estimate was in the range of \$200,000 to \$225,000.

Revenues and Other Benefits. Values of revenues and other benefits were not yet known.

Lessons and Comments. The owners are hoping the technology works. They would like to get manure solids to compost so they can use them for bedding. The designer says farmers installing digesters should expect some downtime.

Information Sources. Mike Koester, NEICC  
Dan Meyer, Iowa State University, Fayette County Extension



## Stencil Farm

*combined phase, mesophilic, plug-flow, flexible cover*

Stencil Farm is a dairy operation in Denmark, Wisconsin. As of May 2002, they had around 850 head, but had a digester built for a planned expansion to 1,200 head. They have several barns and collect manure primarily through scraping with a skid steer. They are using recycled solids for bedding. They decided to install a digester to eliminate odor and provide better fertilizer. The amount of daily manure loaded into the digester was not available. They are using solids separation after digestion with a Fan brand screw press separator.



Digester. They installed a heated plug-flow digester with a flexible cover designed by RCM Digesters, Inc. With a target operating temperature of about 100° F,

the digester (pictured at right) has a storage capacity of about 20 days for 1,200 cows, and is currently running about 22-23 days HRT. They are shooting for a solids percentage of between 9-12 percent for the inputs, and are currently around 9-10 percent. The volume of the digester was unavailable. The dimensions of the digester are approximately 40'W x 110'L x 16'D.

Photo: RCM Digesters, Inc.



## Biogas Use and Other Outputs.

The digester is predicted to produce about 72,000 cfd of

biogas at about a 60 percent methane content. The produced biogas is fueling a 140kW Caterpillar induction engine generator system (pictured at left). They have a contract with Wisconsin Public Service Corporation (WPS) to sell the electricity at an undisclosed tariffed rate. They do net metering, and produced electricity is used on farm with the remainder sold to WPS. Amounts of electricity production and savings thus far were not available. It is not

Photo: RCM Digesters, Inc.



known whether the owner was charged for any system upgrades. Recovered heat is used to heat the digester, the milking parlor, shop and office.

They expect to continue using digested solids for bedding. Digestate is land applied.

Maintenance Needs. Information on maintenance needs was not available.

Project History. The digester was built between June 2001 and January 2002 with the owner acting as the general contractor. As of May 2002 biogas output had not yet stabilized, and was therefore in startup mode.<sup>4</sup> Further details on project history were not available.

System Costs. The total cost of the system is estimated to be between \$400,000 and \$500,000.

Revenues and Other Benefits. They have experienced a significant odor reduction. They expect cost savings from use of biosolids for bedding and sales of electricity. Other information on expected revenues and benefits was not available.

Lessons and Comments. Lessons and comments were not available.

Information Sources. Mark Moser, RCM Digesters, Inc.  
Dick Hauser, Neptune Enterprises  
John Christiano, Wisconsin Public Service Corporation

---

<sup>4</sup> The author received late information that biogas production stabilized in June 2002.

## Tinedale Farms

*two phase, mesophilic/thermophilic, TPAD (mixed), cover unknown*  
Tinedale Farms is a dairy operation in Kaukauna, Wisconsin. They have around 2,400 cows, consisting of 1,500 milking, 200 dry and 700 steers. They use scrape collection for manure into a central pit, and from there it gravity flows to the digester. As of May 2002, they were producing around 45,000 gpd of manure that was fed to a digester designed to handle as much as 60,000 gpd. They plan to use solids separation with a non-agricultural separator after digestion, and use biosolids for bedding. They also hope to get the solids rated "class A" so they can be used for more things.



Digester. Ag Environmental Solutions designed and built a temperature phased anaerobic digester (TPAD) for Tinedale Farms. The TPAD was retrofitted into a plug flow digester but is described as a kind of complete mix digester. The digester is designed to include a thermophilic phase that heats the manure to approximately 130° F. Then it is cooled through a heat exchanger down to 95-100° F for the mesophilic stage. The thermophilic tank can hold about 300,000 gallons and the mesophilic phases can hold about 600,000 gallons. The digester is fed at a fairly constant rate since cows are milked on the farm 23 hours per day. The target solids content for the digester is 9-10 percent, but they have recently averaged about 8.5 percent. The digester is horseshoe-shaped, and its dimensions are 70'W x 135'L x 16'D. The HRT for the digester is 15 days, but they are currently working at about 20 days due to the smaller loading.

Running as mesophilic only, the digester was producing biogas at a rate of 100-115 cfm, and they expect it to produce around 200 cfm or about 290,000 cfd when running TPAD.

Outputs and Uses. They will use the biogas to fire two 375kW Waukesha low NOx engine generator sets.<sup>5</sup> The owners expect to sell all the electricity to the utility WE Energies, and use process heat to heat the digester. They may have excess heat but have not yet planned to use it. Details about their contract with the utility were not available. They will use a non-agricultural screw press solids separator to remove digested solids which will then be used for bedding and possibly sold for other uses depending on whether they get a class A biosolids rating. The digestate will be land spread on about 4,500 acres.

Photo: Wisconsin Focus on Energy



<sup>5</sup> The photo depicts Tinedale Farms' two 375kW Caterpillar engine generators. Photo courtesy of Wisconsin Focus on Energy, Pat Meier, Wisconsin Division of Energy PowerPoint presentation to the National Association of State Energy Officials, February 11, 2002.

Maintenance Needs. Maintenance information for the system was not available.

Project History. The digester was built over two construction periods and there was some idle time while changes were made. Its first startup period was June 2001 through September 2001. This went smoothly while they were doing only mesophilic, but upon switching to TPAD (i.e., adding the thermophilic stage) they recognized an equipment problem: their heat exchanger, which was needed to cool down the manure from the thermophilic stage prior to it entering the mesophilic tank, was undersized. Therefore, the manure entering the mesophilic tank was too hot for the microbes. They attempted running as TPAD from October 2001 through December 2001, then had to revert to mesophilic only. As of June 2002 they were operating steadily using mesophilic only, but expected to start thermophilic again with a new larger heat exchanger in July 2002.

System Costs. System cost information was not available.

Revenues and Other Benefits. The owners expect to produce enough electricity "to power 250 homes" when running the TPAD. More precise estimates of expected system output were not available. The system is fully computerized and can be monitored and controlled remotely. They also expect to save costs on bedding by using biosolids and expect revenues from sales of biosolids.

Lessons and Comments. Lessons or comments for this system were not available.

Information Sources. John Katers, University of Wisconsin – Green Bay

## Top Deck Holsteins

*combined phase, mesophilic, plug-flow, fixed cover*

Top Deck Holsteins is a dairy operation in Westgate, Iowa. The farm has a herd of 700 cows that produce approximately 20,000 gpd of manure or about 28 gallons per cow. Manure is collected mostly with automatic scrapers but they are also flushing one barn. The target solids content is eight percent, but they have a range of about seven to 13 percent solids. They use rice hulls and mattresses for bedding. Use of the mattresses keeps need for other bedding to a minimum. They plan to eventually use digested solids instead of rice hulls. They currently (May 2002) have no solids separator, but plan to add one post-digestion, and also hope to add underfloor forced air assist for drying of solids.

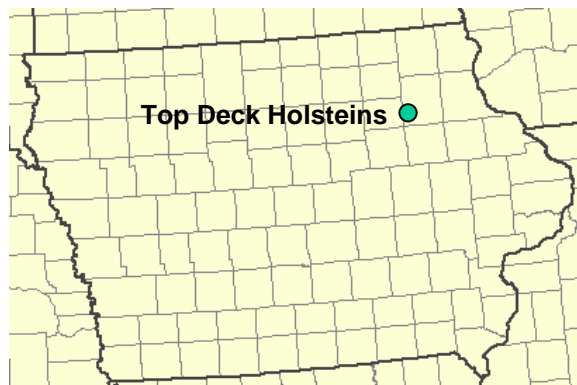

Digester. They installed a heated plug-flow digester, with a preheat tank (that does 78 percent of the heating), designed by Dan Meyer of ISU Agricultural Extension and Ray Crammond of AGRIN, LLC (see illustration below). The digester has a fixed lid and a target operating

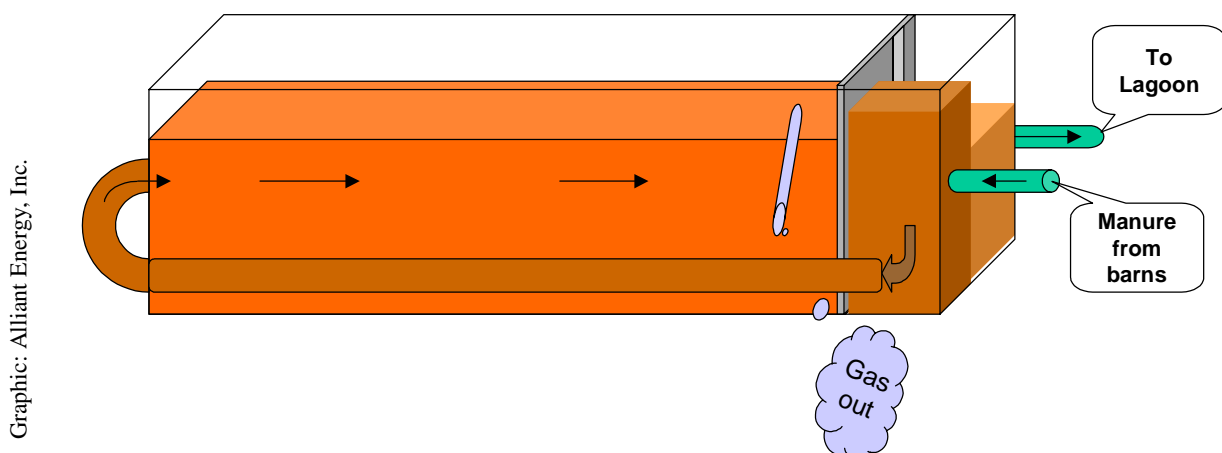

temperature of 98° F. They have installed the capability for RAS but have not yet used it. They plan to use a blower to push the biogas to the engine generators and keep up the necessary pressure. The digester can hold a maximum of 14 days of manure production or about 300,000 gallons. The design HRT of 14 days is shorter than the usual 20 days due to the pre-heating tank.

The digester dimensions are approximately 27'W x 124'L x 12'D.

Outputs and Uses. They expect biogas output of about 52,000 cfd with about a 63 percent methane content. The produced biogas will fire two systems: a 100kW Waukesha induction engine generator set, and a 30kW Capstone microturbine. The engine was attached first because the gas delivery system for the microturbine arrived later. They plan to produce electricity and capture waste heat. They have a contract with Alliant Energy in which the utility agrees to pay them an undisclosed amount per month using a scaled rate structure, but not net metering. Their predicted electrical production is about 832,000 kWh/year. The heat will be used to heat the digester, milking parlors, hot water for pipeline washing, parlor cleaning and floor heat in the alley building.

They expect to eventually rely solely on digested solids for bedding. Digestate will be land-applied using injection.

Maintenance Needs. They expect to change the engine oil every 1,000 hours of operation. The other maintenance needs of this system were not available.

Project History. The anaerobic digester was built as part of an expansion for the dairy from October 2000 through March 2002. The digester was initially started at the end of January 2002. As of May 2002 it was going through a new startup.

During the first startup (January 2002) they ran it for 3 weeks but had foaming and manure solids coming up the pipe. They put the engine generator building 40' away from the digester for safety, but now need to add a blower to move the biogas to the engine. They installed some 10" PVC pipes at a 45° angle for emergency access to the digester. They also had to wait for some parts to arrive for the turbine. Detailed history from the owner was not available.

System Costs. The digester and associated equipment costs are estimated to be about \$140,000, and the estimated cost for the energy generation equipment and structures is about \$250,000. The total cost to make the system operational was around \$390,000. Adding a system for separating and composting solids is predicted to cost approximately \$80,000.

Revenues and Other Benefits. Predicted revenues from electricity sales are not available. They are currently paying about \$30,000 per year in bedding costs, which they expect to avoid when digested solids are used.

Lessons and Comments. No lessons or comments from the owner were available.

Information Sources. Dan Meyer, Iowa State University, Fayette County Extension  
Duane Hanusa, Alliant Energy, Inc.

## *Wholesome Dairy*

*combined phase, mesophilic, plug-flow, gas mixing, fixed cover*

Wholesome Dairy is a dairy operation in Hilbert, Wisconsin. They have 3,000 cows that produce between 60,000 and 66,000 gallons (20-22 gallons per cow) of manure per day. As of early June 2002, they were using rice hulls and recycled solids for bedding, but planned to switch to all recycled solids in mid-June. They have installed an auger-type squeeze separator for post digestion solids separation. The percent solids in the influent was not known. The dairy uses scrape collection with a skid steer to a central pit, where it gravity flows into the digesters.



Digester. Wholesome Dairy installed two mixed, heated plug-flow digesters that share a common effluent exit point. The designer was GHD, Inc. The digesters are both straight, and are placed end-to-end. The digesters have gas-induced mixing and RAS. The digesters have a capacity of about 25 days, and were operating at about 25 days HRT in June 2002. Each digester is approximately 288'L x 36'W x 15.5'D. The target operating temperature is 100°F.

Outputs and Uses. Volume of biogas output was not available. However, the system was running at about 500kW plus flaring excess gas in June 2002. The methane content was between 52 and 56 percent. The biogas fuels a 508 kW capacity Deutz synchronous (i.e., can operate independent of utility phase) engine generator set. They expect to sell all electricity and use the waste heat for the digester, dairy, and manure solids drying. They were using some digested solids for bedding. Digested effluent is land spread, injected and irrigated.

Maintenance Needs. Routine maintenance needs were not yet known.

Project History. The digester was built at the same time as the dairy over a 9-10 month period starting in spring 2001. They started feeding and heating the digester at the end of April 2002. As of June 2002, it was still in startup mode. They had numerous costly delays mostly related to generator commissioning.

System Costs. They experienced many costs associated with delayed startup. Specific costs associated with this system were not available. The owner estimates the total cost to be approximately \$1.3 million. The owner also paid a portion of utility rewiring costs.

Revenues and Other Benefits. All electricity produced is sold to WPS at an undisclosed rate plus an adder for market value of the renewable energy credits. They do not yet have estimates of savings from bedding replacement and waste heat use.

Lessons and Comments. They have felt the project was a serious financial and management drain, and would not go through it again. As of June 2002, the owners had yet to see a significant period of full operation, and therefore had seen insufficient benefits to justify the costs they incurred.

Information Sources. Kenn Buelow, Wholesome Dairy  
Steve Dvorak, GHD, Inc.  
John Christiano, Wisconsin Public Service Corporation



## Operational Digesters

### *Apex Pork*

*combined phase, mesophilic, complete mix lagoon, bank-buried floating cover*

Apex Pork is a swine finishing facility in Rio, Illinois. The herd size is typically around 8,300 head. The daily volume of manure produced is unknown. The facility has recently changed to an all-in all-out management strategy resulting in variable amount of manure produced that can be collected. They use a pull plug collection method (when all-in). The percent solids of the manure was not known. The farm applies about 4 million gallons of manure per year to their fields.

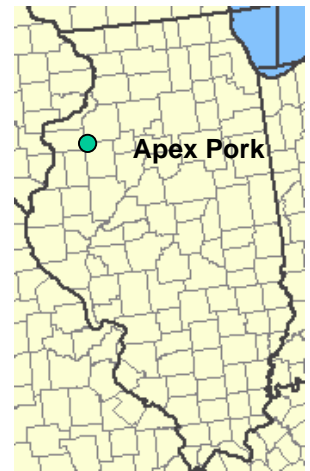

Digester. RCM Digesters, Inc., designed a heated, covered, mixed earthen lagoon as an odor control system for Apex (pictured below). This complete mix digester has a bank-buried, insulated floating cover to keep out rain and oxygen, and collect biogas. The digester has a volume of approximately 800,000 gallons, and can hold between 18-20 days worth of manure production. The digester's dimensions are 120' x 160' x 16'D. The digester is heated using a heat rack made out of 3" black steel pipe.

Photo: RCM Digesters, Inc.



Outputs and Uses. Recent biogas production levels are unknown because the gas meter broke and was not yet replaced. However, in mid-summer 1998, the digester was producing 36,000 cfd (prior to all-in all-out management). The biogas is used to run a Burnham boiler (pictured below) that serves the sole purpose of heating the digester. Excess biogas is flared. Digestate is land spread on croplands with a corn and soybean rotation.

Maintenance Needs. The system requires about 10 minutes per day of maintenance at an annual cost of less than \$1,000. They must make sure the boiler is burning at a high enough temperature to avoid condensation that causes corrosion.

Project History. The digester went through two startups, both of which took about 30 days of using propane heat before the boiler could run on biogas. The first startup was in May 1998. The second startup followed storm damage to the cover in summer 1998. They changed covers (i.e., put in a bank-buried, insulated floating cover), and switched to all-in all-out management after that. The second startup began in December 1998.

Since then, the digester has been subjected to fluctuating loads due to the management style. They let it go dormant during slow periods, they then start it back up as needed. They have been able to restart the digester each time without incident.

Early on, they were having problems with condensation in the boiler because they were running it at too low a temperature. They have since changed the design a little and put in a secondary loop and an additional circulating pump.

If the boiler operates below 140°F, it will stop sending hot water to the digester for a while until the temperature reaches 140°F again. As of June 2002, the system was operating normally given the inputs.

Photo: RCM Digesters, Inc.



System Costs. The digester itself cost about \$66,700, and the boiler and gas handling equipment cost about \$85,600, for a total cost (including changes) of about \$152,300.

Revenues and Other Benefits. The digester was installed as an odor control measure. The owners had received some complaints from neighbors, which have stopped since installation. The US EPA approved of the digester. The owners also feel their stress levels are lower and their neighbor relations have improved.

Lessons and Comments. The owners have had odor complaints and the EPA became involved. They took this aggressive step to take care of the odor problems. Both the EPA and their neighbors liked the concept. Installation stopped the complaints. While the costs may seem high for purely an odor control measure, the owners feel it was money well spent.

Information Sources. Glenn Saline, Apex Pork  
Mark Moser, RCM Digesters, Inc.

### *Baldwin and Emerald Dairies*

*combined phase, psychrophilic, covered lagoon, bank-buried poly cover*

The Baldwin and Emerald dairies, located in north-western Wisconsin are profiled together because they are owned by the same people and are very similar. The owner decided to install covered lagoons to control odors from the dairies' manure storage facilities. The herd sizes for Baldwin and Emerald dairies are 1,100 and 1,600, respectively. They estimate about 25 gallons of manure per cow per day (including parlor wash water) is generated and scraped raw to the lagoons. Emerald uses wood shavings for bedding, and Baldwin uses sand (they have a sand separator that takes about 98 percent out). They estimate that the inputs to Emerald lagoon have about six percent solids. The solids content of inputs to the Baldwin lagoon are unknown. They currently do not employ solids separation, but may explore that option to reduce volume.

Digester. The owner chose to install two covered lagoons, designed by Tiry Engineering, to control odor from stored manure and keep precipitation out. The digester also generates biogas, with seasonal variations in gas content, and reduces



Photo: Baldwin and Emerald Dairies



Photo: Baldwin and Emerald Dairies

volatile solids. The Baldwin lagoon, constructed in 1998, is clay-lined. The Emerald lagoon, constructed in 1999, is poly-lined. The Emerald lagoon is 208' x 900', and the Baldwin dimensions were unavailable. The above picture shows the Emerald lagoon under construction. The picture on the left shows the Emerald cover and gas collection pipe. The

lagoons are not currently heated or mixed. The Baldwin lagoon can hold about 7 months of manure production and the Emerald can hold about 12 months of production. Manure is stored and field applied in the spring and fall each year.

Biogas Use and Other Outputs. They are currently flaring biogas from these lagoons, which is produced year round. The methane content of the gas ranges from 60 percent in the summer to 40 percent in the winter. They have recently started metering it. They are exploring options for using the biogas and may try heating portions of the lagoons to increase biogas production. They are also checking into options for water clarification. The lagoon manure is delivered to the fields for application using a drag hose system instead of tanker trucks. The manure is then injected into the soil reducing odor and risk of runoff. The picture below shows the cover bubbling up with biogas produced during the winter.

Photo: Baldwin and Emerald Dairies



Maintenance Needs. Very little maintenance is required.

Project History. The Baldwin lagoon cover was installed in 1998 and the Emerald was installed in 1999. They have had no serious problems with these lagoons.

System Costs. The Baldwin lagoon required a \$70,000 investment for the cover and gas collection equipment. The cost for the Emerald lagoon cover and equipment was \$125,000. The costs for the constructing the lagoons themselves are unknown.

Revenues and Other Benefits. They have reduced the volume of manure to be treated and field applied by excluding precipitation. They are exploring options for further reducing the volume. One possibility is to install solids separation before the lagoon. The main benefit has been a greatly reduced odor for everyone in the neighborhood. They are also getting some volatile solids (VS) reduction through digestion. This means they do not need to agitate the manure in the lagoon prior to pumping it out to the fields, and the manure pumps easier.

Lessons and Comments. The owners feel these covered lagoons are efficient, low cost, low tech solutions to odor problems. They suggest, however, that there may be better long-term solutions.

Information Sources. John Vrieze, Baldwin and Emerald Dairies

## Bell Farms

*combined phase, mesophilic, complete mix, flexible top*  
Bell Farms (formerly Swine USA) is a swine farrow and gestation facility in Thayer, Iowa. Their typical herd size is 5,000 sows. They produce about 21,000 gpd of manure, of which 16,500 is fed to a digester. The solids content of the manure is variable, but was recently measured at about 0.4%. Manure is collected using a pull plug system.

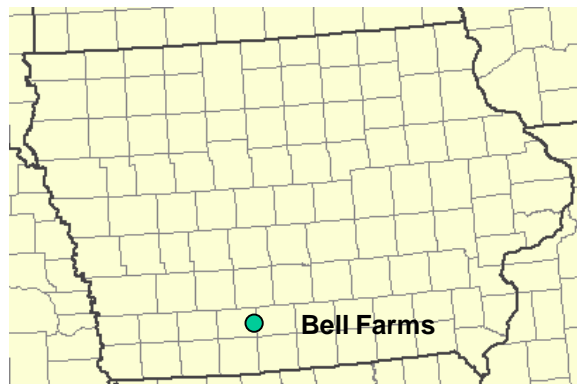

Digester. Swine USA was an AgSTAR charter farm. RCM Digesters, Inc. was paid with AgSTAR funds to

design a heated complete mix digester, pictured at right. Bell Farms has since purchased the farm and digester. The digester has two agitators and is mixed twice daily. It has a flexible, inflatable vinyl cover. The overall capacity of the digester is about 700,000 gallons, and the average HRT is about 20 days. The dimensions of the digester are 70' x 90' x 16'. The target operating temperature is 100°F.

Photo: RCM Digesters, Inc.



The figure below shows the general layout of the farm buildings and digester (not drawn to scale).

## Biogas Use and Other

Outputs. The digester was producing approximately 30,000 cfd at a methane content of about 65 percent before a recent decline in production after a change in ownership and operations. The biogas fuels an 80 kW (rated 75kW for biogas) caterpillar 3306 engine generator set. They have averaged about 1,090 kWh per day (although lower recently). Their current status regarding utility contract and electricity use or sale is not available. In 2000, they reported annual electricity savings of between \$35,000 and \$46,000.

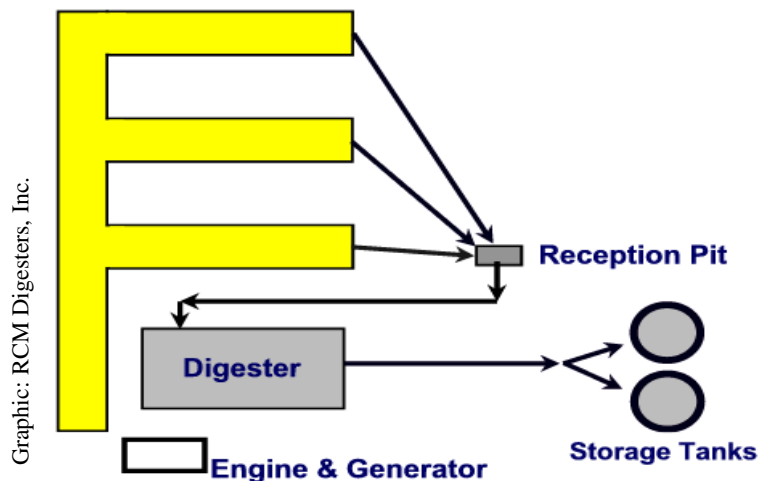

Graphic: RCM Digesters, Inc.

Waste heat is recovered and is used to heat the digester. Any excess biogas is flared. They have been replacing some commercial fertilizer on neighboring croplands with digestate.

Maintenance Needs. The system requires 2 hours per day for operating the manure collection and digester and engine generator set. They have to manually start the pumps, and monitor temperatures. They change the engine oil every 500 hours.

Project History. The digester was installed, mainly for odor control, as part of the new farm construction starting in 1998. They started filling and heating the digester over a 90-day period from June 1999 through August 1999. The startup was longer than usual because they were still populating the farm with pigs at that time. As of September 1999, they felt they were achieving full biogas yield. They had some problems working out a utility contract and dealing with inconsistencies in intertie requirements.

They had an early engine failure (replaced under warranty at no cost to the owner) and a blown fuse, both resulting in some down time. Given these outages, they estimate that the digester and generation equipment have been operational about 90 percent of the time since installation.

Bell Farms bought the operation in 2001, and is working on management issues that will improve the operation of the digester. Since Bell Farms ownership, the biogas production of the digester has dropped. They are working to increase the solids content through improved water management in the barns, which they feel is the biggest issue with the production decline.

System Costs. While itemized cost information was not available, the overall cost of the project is estimated at \$576,000 based on 50% matching grant formula. EPA's AgSTAR program provided technical assistance and in-kind support. Swine USA also received financial support from Iowa Department of Natural Resources, Iowa Department of Economic Development, and USDA--Natural Resources Conservation Service for approximately half the total cost. Some system costs may be higher due to requirements for study or monitoring of the digester tied to funding sources.

Revenues and Other Benefits. The system has provided electricity-offset savings between \$35,000 and \$46,000 per year. The owners appreciate how effectively the digester controls odors and captures methane. They hope to bring in some revenue by using digestate to replace \$20 to \$50 of commercial fertilizer per acre on neighboring croplands.

Lessons and Comments. The owners recognize their need to control the variability and reduce water content of the digester inputs. They are actively exploring management options to better use their digester.

They suggest that it is best to work with a service dealer (for the energy generation equipment) who is close, or have someone trained to service it nearby because it can require "intense management" at times. They commented that the digester system they have helps add value to an agricultural byproduct.

Information Sources. Mike Erwin, Bell Farms  
Mark Moser, RCM Digesters, Inc.  
Jeff Lorimor, Iowa State University

## Fairgrove Farms

*combined phase, mesophilic, plug-flow, fixed top*

Fairgrove Farms is a dairy farm in Sturgis, Michigan. Their herd size is approximately 500 cows, and produces between 8,000 and 9,000 gpd of manure. The owners, John and David Pueschel, have recently sold the herd to another family who are now running the milking operation and leasing the facilities. The Pueschels, however, remain owners of the farm and manage the digester. The solids content of the manure fed to the digester is 13 percent. They use solids separation after digestion with a Vincent screw press separator and they use recycled solids for bedding. Manure is collected using a scraper system.



Digester. Fairgrove Farms hired Perennial Energy to design a buried, heated plug-flow digester (see schematic below). This digester is now one of the oldest functioning anaerobic digesters for animal manure in the United States. The digester dimensions are 120' x 24' x 8' at the edges to 12' in the center (floor is V-shaped). The digester volume is 180,000 gallons or about 18 days

Graphic source: GLRBEP

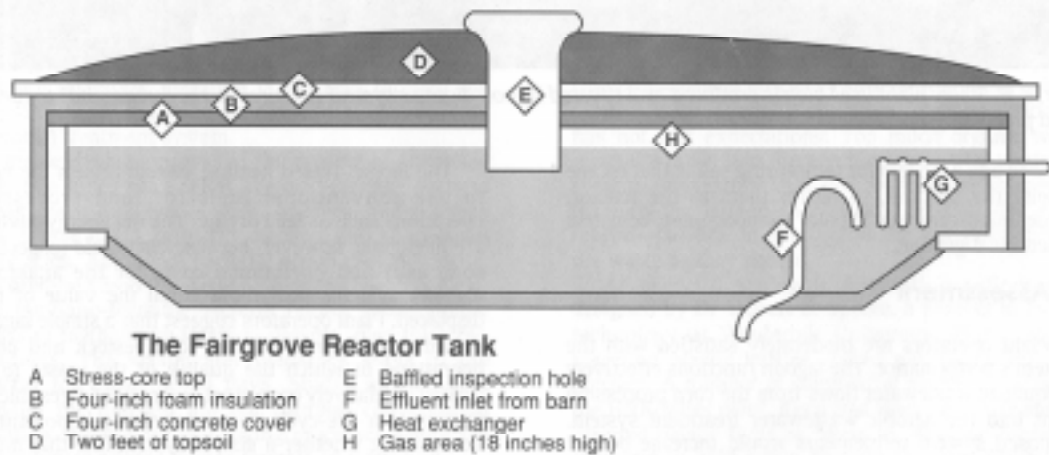

of manure production. The HRT has historically been about 18 days on average, but more recently has risen to 20-21 days. The target operating temperature is 95°F. The picture at right shows an aboveground view of the digester.

### Biogas Use and Other Outputs.

The digester has historically produced about 40f<sup>3</sup>/minute of biogas, but has recently been producing about 30f<sup>3</sup>/minute. The biogas, which has a

Photo: Fairgrove Farms



methane content of 60 percent, is used to fuel a Caterpillar 3306 85kW engine generator system. The system can generate 70kW using biogas, but requires 40f<sup>3</sup>/minute of biogas to do so. They have figured out that by adding a little LP gas, they can run the engine wide open, and they actually earn about \$3 in electricity for every \$1 of LP gas they burn with the biogas. (If they were to run it with 30f<sup>3</sup>/minute of biogas, they would have to keep it in fast idle and generate 50-55kW.) They estimate that the digester has earned \$130 per day for the last 20 years.

They think the recent drop in biogas production may be due to a change in feed. The cows are being fed more corn and less hay. Some researchers from Purdue University are studying it and they suspect that the system may require more carbon.

Photo: Fairgrove Farms



They use recovered heat from the engine to heat the digester. They use recycled solids for bedding (replacing the sand bedding they had used before they installed the digester). The photo above shows the recycled solids, and the photo below shows the solids separator.

Maintenance Needs. The system needs to be manually pumped twice a day which takes about 15-20 minutes for a total estimated cost of about \$1,200 per year (at \$10/hour pay rate). They have had two engines in 20 years (they bought a second one after 10 years so they could switch them out for repairs). They still have the first one. They need to replace the pumps every three years and clean out the digester every 5 years due to sand buildup. They have had to replace the heads on the engines. The engine oil is changed every 1,100 hours of operation. They have been fortunate to have a good mechanic on hand to handle minor problems.

Photo: Fairgrove Farms





The engines can be run for about 2.5 years (20,000-22,000 hours) but then need an overhaul. They observed that the engines should avoid brass and bronze because they wear out in 1-1.5 years (these are usually used in gauges).

Project History. The digester was installed in 1981 over a period of about 3 months. It required about a one month period for production to stabilize, and requires a similar startup period after each clean-out. In order for the digester to work properly, the owners switched from sand to digested solids for bedding at the start. The owners maintain that it's the digested solids that make the thing work. They need to replace the screens in their solids separator (pictured on the previous page) four times per year, and have modified the separator every year.

The digester has been working non-stop, except for periodic clean-outs, since installation, which amounts to a 98 percent up time. They seeded it originally with municipal treatment plant digestate. During some cold periods they have had to use some LP gas to run the engine and heat the digester, and with the current drop in biogas production are now adding LP gas regularly (see "Biogas Use and Other Outputs" for more information).

Except for the recent drop in production following a change in feed, biogas production has been fairly steady throughout the digester's life.

System Costs. The digester cost about \$150,000 and the energy generation system cost about \$50,000 in 1981. This amounts to approximately \$380,000 in 2000 dollars.

Revenues and Other Benefits. The digester saved Fairgrove Farms electricity costs of an estimated \$130 per day for 20 years. This amounts to over \$900,000 in electricity savings over 20 years or about \$46,000 per year. An estimate of bedding cost savings from using biosolids was not available.

Lessons and Comments. They discovered that if they run their engine hotter than usual, then the hydrogen sulfide (which causes corrosion of engine parts) was not a big factor.

If they had it to do over again they would put in a separate heated settling chamber where the manure has to go over a wall to remove sand before the digester.

Information Sources. David Pueschel, Fairgrove Farms  
John Pueschel, Fairgrove Farms  
Ted Landers, Perennial Energy  
Ray Crammond, AGRIN, LLC

## Gordondale Farms

*combined phase, mesophilic, plug-flow loop, gas mixing*

Gordondale Farms is a dairy operation in Nelsonville, Wisconsin. They have a herd of 600 cows that each produce an estimated 30 gallons of manure per day (including parlor wash water) for a total of about 18,000 gallons per day. They use a scrape collection method, and solids separation after digestion with a screw-press type separator. They had a one-time tested solids content of eight percent with a target between 9-10 percent. They use recycled solids for bedding. The manure reception pit is heated and the manure is recirculated to the flume to keep it from freezing in the winter.



Photo: Alliant Energy, Inc.

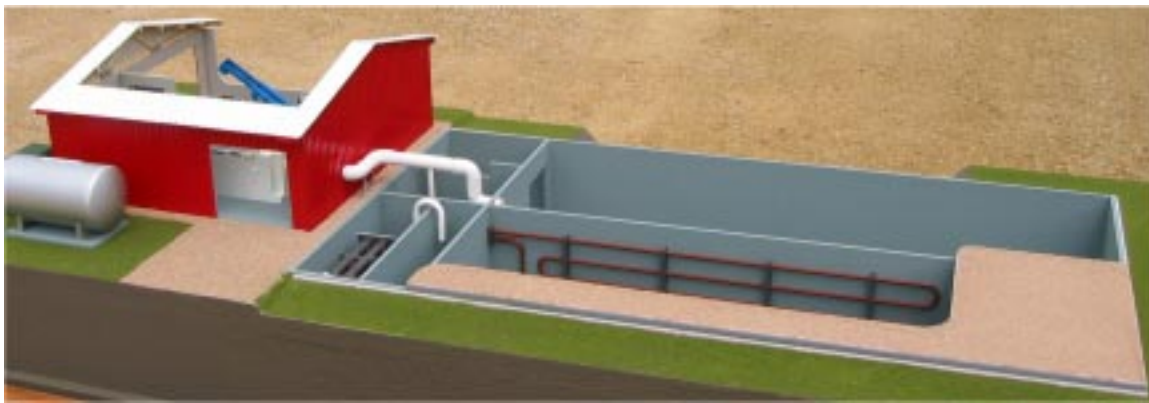

Digester. Gordondale Farms installed a mixed heated plug-flow loop digester designed by GHD, Inc. A picture of the model is included above, and an above ground view of the digester is pictured at right. The owners saw an opportunity with the dairy expansion to incorporate the digester, along with water saving measures and manure transport methods, into the new facility. They chose the loop design because the digester can theoretically be expanded (to accommodate an expansion of the farm) by moving the looped end out farther from the end with all the equipment, the entrance and exit. The digester is mixed through re-introduction of biogas along the bottom of the digester. The upward rising bubbles provide non-mechanical mixing. The cover for the digester is fixed, and they also use RAS. The digester has an HRT of 20 days and an SRT of 25-30 days. The target

Photo: Alliant Energy, Inc.



operating temperature is 100°F. The digester size is 65'W x 108'L x 14'D, and its volume is 650,000 gallons.

Biogas Use and Other Outputs. The biogas fuels a Caterpillar 3406 engine generator set (pictured at right). The set is sold as 150 kW but is rated about 135 kW for biogas. It is an induction generator (phase, frequency and voltage set by the utility). Alliant Energy owns the generation equipment and buys gas from the dairy. The waste heat will be used to heat the digester, dairy parlor, holding area, offices, engine room and possibly the pad for the milk tankers (in winter). They would like to put in an absorption refrigeration unit as well.

They are shooting for biogas output of 6 cows per kWh, but as of June 2002 were producing about 4.5-5 cows per kWh. Alliant put in a gas meter for the engine and one for the flare and pays Gordondale based on kWh generated.

Maintenance Needs. During the short time since the digester has been operational, maintenance has gone fairly smoothly with no serious problems. Information on routine maintenance required for the digester was not available. Alliant Energy maintains the energy generation equipment.

Project History. The digester was built between October 2000 and November 2001, (the farmer did the concrete pour) at the same time the dairy expanded. They started adding manure in November 2001, and started the generator in January 2002. The system was operational in March 2002. The digester has been producing biogas but the exact amount is unknown because gas meters were not installed until summer. In March and April the generators ran at an estimated average output of 100kW, and in May averaged 108kW, due to some problems with engine overheating that have since been resolved. They expect to be able to operate at around 135kW consistently and flare excess gas.

System Costs. The digester cost between \$280,000 and \$300,000, and the generation equipment is estimated to cost approximately \$242,000 (paid by the Alliant).

Revenues and Other Benefits. Gordondale gets paid an undisclosed rate for the biogas. They also will be able to save on propane costs by using waste heat from the energy generation, and save on bedding costs by using the digested solids for bedding. The owners said they may switch to mattresses rather than solids for bedding due to outside interest in use of solids for other things. If that market is strong enough, they may also get some revenues from sales of solids. Because some phosphorus adheres to the solids, by separating the solids before land application, they reduce phosphorus loading to surface waters and the amount of trucking of wastes they need to do.



Photo: Alliant Energy, Inc.

Lessons and Comments. The owners stress you need to have the whole farm involved with the project and working toward making the system a success. Those considering installing a digester need to recognize that it is a long-term commitment. They must agree to make the other necessary changes in operations (such as controlling water use, and not using sand bedding) so that the system will work properly. It's also important to make sure you have a good team (farmer, designer, and utility) to make the project a success. It helps to have a good mechanic who can step in and make adjustments when needed.

Information Sources. Kyle Gordon, Gordondale Farms (presentation at Wisconsin Biogas Symposium, April 2002)  
Steve Dvorak, GHD, Inc.  
Duane Hanusa, Alliant Energy

## Haubenschild Farms

*combined phase, mesophilic, plug-flow, flexible top*

Haubenschild Farms is a dairy operation in Princeton, Minnesota. They have a herd of 750-850 milking cows and use a scrape method of collection. They produce between 20,000 and 22,000 gallons of manure per day (or about 28g/cow/day). They use shredded newspaper for bedding (about six tons per week) and have a solids content for influent of about 9 to 9.5 percent. They do not use solids separation. As a water conservation measure, they use all wash water at least twice. They have a goal of being as environmentally friendly as possible, and work on sustainable operations over time. The graphic below illustrates the general layout of the farm.

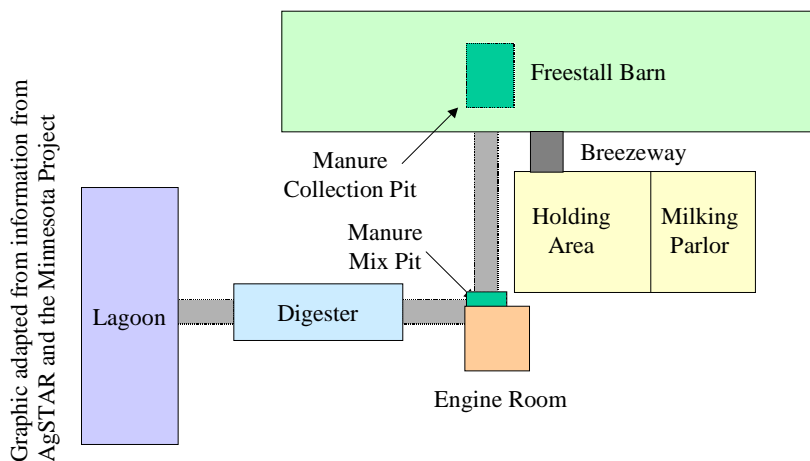

Digester. They installed a heated plug flow digester using RCM Digesters, Inc. design. The design work was paid for by USEPA AgSTAR contract. The photo below shows the digester with the flexible cover. The digester target operating temperature is 100°F. It has a volume of about 400,000 gallons, and is 150'L x 30'W x 14'D. The design HRT is 20 days, and

they were operating at an HRT of about 21 days as of May 2002. The digester does not use RAS.

Biogas Use and Other Outputs. As of May 2002 the digester was producing nearly 80,000 cfd of biogas, with a methane content of about 62 percent. The amount of biogas produced is higher than they had predicted for the digester. They think this may be related to the use of shredded newspaper bedding and/or the slightly longer HRT than design. They use 72,000 cfd to fuel a

Photo: RCM Digesters, Inc.



Caterpillar 3406 150 kW induction engine generator set (photo on next page), and the excess is flared. The owner also adds about 1 gallon of propane per day. They also use the recovered heat to heat the digester, milking parlor, alleyway and they store hot water in a 180 gallon tank

for reserve if the power goes out. Their system is using about 23 ft<sup>3</sup> of biogas per kWh of electricity generated. The digestate is land applied.

Maintenance Needs. They change the spark plugs once per year, and change the engine oil after every 1,000 hours of operation. The engine needs to be overhauled periodically (but as of April 2002 had not yet needed one). They perform routine maintenance and checks of the blower, pipes, flare, pumps and do routine operations which take about 45 minutes per day. The system has been operational over 98 percent of the time since installation. Dennis Haubenschild thinks the overall labor needed for manure handling is actually lower now than it was before the digester was put in.

Project History. The Haubenschilds originally looked at putting in a digester in the 1970's to make manure more plant available. They built the digester from March 1999 through July 1999, as part of an overall expansion of their

Photo: RCM Digesters, Inc.

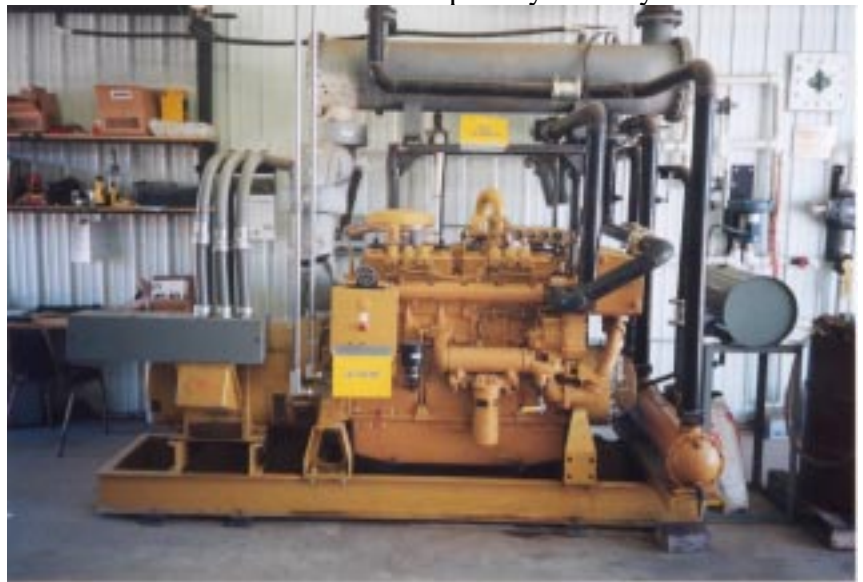

operation. The owners did a lot of the construction themselves. In July 1999, they started warming the manure, and started producing biogas in September of that year. In May 2002, they had 23,700 hours of operation on their engine. Dennis Haubenschild watches the digester closely to make timely adjustments if it strays from recommended operating parameters. They have had two drops in biogas production – both temperature-related. If the temperature goes below 96°F or above 102°F production drops off. They do not pre-heat the manure going in.

The hydrogen sulfide levels in their biogas have been extremely low (in the parts-per-billion range) meaning they have less wear on the engine. They have also benefited from having a supply of essentially free newspapers (they only pay for the hauling), which they shred themselves to use for bedding.

System Costs. The digester and energy generation equipment were predicted to cost \$307,700. The system ended up costing about \$355,000. They built in extra wiring and plumbing for contingencies and experiments, which drove up the price. The Minnesota Department of Agriculture offered them a \$150,000 no-interest loan for the project and that got them started. They became an "AgSTAR Charter Farm" making them eligible for design and operational assistance, which they received at an estimated value of \$40,000. The Minnesota Department of Commerce and the Minnesota Office of Environmental Assistance offered them grants totaling \$87,500 for construction. Haubenschild Farms paid the remaining \$77,500 directly. They estimate maintenance costs of about \$3,700 per year.

Revenues and Other Benefits. They originally sought to recoup their costs mainly through sales of electricity. However, the digestate has enhanced value as a fertilizer over raw manure. They

estimate \$40,000 savings annually by substituting digestate for commercial fertilizer. Under a five-year contract with East Central Energy Cooperative, Haubenschild Farms sells electricity to the utility at a rate of \$0.073/kWh (which changed from \$0.0725/kWh in 2001). For the 12-month period from June 2001 through May 2002 they estimate electricity offset savings of \$37,000, and revenue from electricity sales of \$39,000.

They estimate that use of process heat from the engine is saving them about \$4,000 per year in propane costs. They also have some amount of fuel and time savings from not needing to agitate the manure in the storage area prior to application (the digester has allowed them to stop using a mechanical mixer). Also, the lower odor has given them more flexibility with application of digestate to fields. The cost of one odor-related lawsuit would pay for two digesters.

Lessons and Comments. The use of a digester at a dairy has to be part of the overall plan for managing manure. It is extremely important to first look at water conservation and reduce water use to the extent possible.

They treat the digester like another animal on the farm. They feed it two times per day, and make adjustments if it displays symptoms suggesting it's not working right (they monitor CO<sub>2</sub> content in biogas about once a month or if there appears to be a problem).

Information Sources. Dennis Haubenschild, Haubenschild Farms  
Mark Moser, RCM Digesters, Inc.  
Carl Nelson, The Minnesota Project  
Dick Hauser, Neptune Enterprises  
Ag Innovation News, July 2001 Article

## Maple Leaf Farms

*combined phase, mesophilic, mechanical mix, fixed top*

Maple Leaf Farms is a duck operation in Franksville, Wisconsin.

They typically have an animal population of about 500,000 ducks.

Some farms use pine shavings for bedding but most barns have wire floors and scrapers collect the manure and wash down water. They then pump the scrapings into a large holding tank (2.5 million gallons) before the digester, where input is equalized. They produce about 50,000 gpd of manure with a solids content of about 1-2.5 percent (they were at 1.5 percent at the time of the survey). They use an internally fed roto-drum screen for solids separation prior to digestion. The solids are then composted, and ultimately land applied.



Digester. They installed a mesophilic complete mix digester designed by Applied Technologies, Inc. They have a storage tank before the digester where the grit drops out. Then the effluent goes into the digester (through the side of the mixing chamber) where biosolids are pumped through the heat loop. The digester mixes the manure using low speed mixers. After the digester, the grit or struvite<sup>6</sup> settles out and the effluent is sent to an activated sludge basin where it is aerated, and then on to the final gravity clarifier. The digester has a six-day design HRT, but was operating at about 5 days as of May 2002.

The digester itself is a cylinder 30' high, and 60' in diameter, with a volume of about 400,000 gallons. It can hold 5 days of production at their current output (when they first built it the digester held seven to ten days of their output). The bottom, walls and cover are all reinforced concrete.

Biogas Use and Other Outputs. The digester produces biogas at a rate of about 40-50 cfm and methane content of about 70 percent. Until early 2002, biogas was flared and they had a separate natural gas-fueled boiler to heat the digester. In early 2002 they added a combined heat and power system and began using waste heat from the engine to heat the digester. They installed a Hess 200 kW generator with a Daiwoo engine. They predict steady generation of about 200kW (based on about a 95 percent up time) for an annual production of about 1.6 million kWh per year. They will use recovered heat for the digester, offices, lab, and utility building.

Separated solids are land applied. Digestate is treated with activated sludge aeration after digestion and spray irrigated.

Maintenance Needs. Their operation and maintenance program for the digester has become "100 percent more effective" with some modifications in materials used and preventative maintenance measures. For example they have minimized the effects of struvite buildup in the digester through regular valve attention. They plan to clean their heat exchanger on a quarterly

---

<sup>6</sup> Struvite is a white crystalline substance consisting of magnesium, ammonium and phosphorus in equal molar concentrations (Parsons et al., no date).



basis. The routine maintenance of the digester costs them about \$20,000 per year, and they have a maintenance agreement with Wolter Hydraulics and Generators, which covers the generation equipment for \$0.011 per kWh.

Project History. As odors from their operation became a growing issue due to land development around them, Maple Leaf Farms installed an anaerobic digestion system to minimize the problem. The system was installed in 1988 over a period of about 3 months. They originally had startup problems, in which the microbes died, resulting in effluent that was undigested. In about six months they had it running smoothly. They need to clean it out every 5-8 years, and have done so once so far (they are due for another clean out soon). After their one clean-out, they had it running smoothly again in about a month. The system has been operational since 1988, and the digester has been running 100 percent of the time except for during the clean-out period. They installed a combined heat and power system in 2002 and were able to replace the propane boiler they were using to heat the digester. They ordered a special switch to allow their generator to act as a backup generator for the wastewater treatment plant (i.e., a synchronous generator that could operate independent of the utility if needed). They have spent about six months debugging the energy generation system and figuring out what kind of routine maintenance it needs with their operation.

System Costs. The digester design and installation cost about \$350,000 in 1988 (about \$509,000 in year 2000 dollars). The energy generation system cost \$270,000 in 2002. This included the special transfer switch to allow synchronous generation (\$10,000). They also had purchased a special heat exchanger in anticipation of participating in a microturbine research project. The project then fell through, rendering the heat exchanger marginally useful. They received a \$65,000 grant from the Wisconsin Department of Agriculture, and they will also receive federal tax credit for making electricity from poultry manure.

Revenues and Other Benefits. They have signed a two-year contract with WE Energies for electricity sales. They predict that they will be able to offset electricity costs with savings of about \$60,000 per year (based on a power sales rate of \$0.05/kWh), and add about \$18,000 in revenues from electricity sales. They sell all electricity to WE Energies, but have a net metering agreement where they are paid a higher rate for their net energy sold. Maple Leaf Farms gets a premium of \$0.011 per Kw. This is equal to the maintenance contract cost. They are paid a total of \$0.061/kWh for the electricity generated.

They also predict savings of about \$50,000 per year on propane costs based on a \$0.75/gallon price of propane.

Lessons and Comments. If they were to do it over again, they would probably do more of the engineering and construction work themselves. Installing a digester has allowed them to continue to operate at their current location and be good neighbors as the city grew around them.

Information Sources. Bob Rosdil, Maple Leaf Farms  
John Kouba, Applied Technologies, Inc.

**CHAPTER 4**  
**TABULAR CASE SUMMARIES**

This chapter presents the information from the case studies in tabular format. This format allows easier comparison of specific characteristics across all cases. Information is grouped into the following subsets: farm, digester, digester outputs, cost, and digester history.

#### Farm Information Subset

Farm Name	State	City/Town	Type	Herd Size	Manure Collection	Daily Manure Treated
<b>CONSTRUCTION</b>						
Herrema Dairy	IN	Fair Oaks	dairy	3,500-4,000 cows	scrape	123,000 gpd* (predicted)
New Horizons Dairy	IL	Elmwood	dairy	1,250 (will be 2,000 in Sept '02)	scrape	40,000 gpd (expected at 2,000 cows)
Northern Plains Dairy	MN	St. Peter	dairy	3,000 Jersey cows	scrape	60,000 gpd (~20 gal/cow/day)
<b>STARTUP</b>						
Crawford Farm	IA	Nevada	swine finishing	2,800 head (all in all out)	pull plug, scraper system	29,000 gpd (10.5 gal/sow/day)
Double S Dairy	WI	Markesan	dairy	700 milking cows ~730 feeding (design 1k) digester	flush	21,000 gpd (estimated) (30 gal/cow/day)
Futura Dairy	IA	Central City	dairy	420 cows (design 750)	scrape	10,000 gpd (estimated 25 gal/cow/day)
Northeast IA CC Farm	IA	Calmar	dairy	170, 100-120 cows feed digester	automatic and tractor scrapers	4,400 gpd (~40 gal/cow/day)
Stencil Farm	WI	Denmark	dairy	850 cows (design 1,200)	scrape and skid steer	not available
Tinedale Farms	WI	Kaukauna	dairy	1,800 cows	scrape to pit then gravity flow	45,000 gpd, (designed for 60,000)
Top Deck Holsteins	IA	Westgate	dairy	700 cows	automatic scrapers	20,000gpd
Wholesome Dairy	WI	Hilbert	dairy	3,000 cows (2 digesters)	scrape then gravity flow	66,000gpd (22 gal/cow/day)
<b>OPERATIONAL</b>						
Apex Pork	IL	Rio	swine finishing	8,300 head	pull plug	~11,000 gpd
Baldwin Dairy	WI	Emerald	dairy	1,100 cows	scrape	27,500 gpd
Bell Farms	IA	Thayer	swine farrow & gestation	5,000 sows	pull plug	21,000 g/day (feed 16,500 gal/day)
Emerald Dairy	WI	Emerald	dairy	1,600 cows	scrape	40,000 gpd
Fairgrove Farms	MI	Sturgis	dairy	500 cows	scrape	8,000 to 9,000 gpd, (~15 gal/cow/day)
Gordondale Farms	WI	Nelsonville	dairy	600 cows, 800 cow (capacity)	scrape	18,000 gpd
Haubenschild Farms	MN	Princeton	dairy	750-850 milking, ~900 total	scrape	22,000 gpd, (28 gal/cow/day)
Maple Leaf Farms	WI	Franksville	duck	500,000 ducks	scrape dry bedding and wire floor, wash into tank	about 50,000 gpd

\* gpd = gallons per day

## Digester Information Subset

Farm Name	Phases	Temperature Category	Type	Cover	Design HRT	Practice HRT
<b>CONSTRUCTION</b>						
Herrema Dairy	combined	mesophilic	plug flow loop (x2)	fixed	20 days	not available
New Horizons Dairy	combined	mesophilic	plug flow (x2)	flexible	20 days	not available
Northern Plains Dairy	combined	mesophilic	plug flow	flexible	20 days	not available
<b>STARTUP</b>						
Crawford Farm	two phase	mesophilic*	ASBR	flexible	15 days	not available
Double S Dairy	combined	mesophilic	plug flow loop	fixed	20 days, SRT 25-30 days	not available
Futura Dairy	combined	mesophilic	plug flow loop	fixed	20 days, SRT 25-30	not available
Northeast IA CC Farm	combined	mesophilic	plug flow	fixed	13-14 days (shorter if MPW included)	not available
Stencil Farm	combined	mesophilic	plug flow	flexible	20 days	22-23 days
Tinedale Farms	two phase	mesophilic/thermophilic	TPAD	undisclosed	15 days	20 days
Top Deck Holsteins	combined	mesophilic	plug flow	fixed	14 days (shorter because of preheating)	not available
Wholesome Dairy	combined	mesophilic	plug flow (x2)	fixed	20 days	25 days
<b>OPERATIONAL</b>						
Apex Pork	combined	mesophilic	complete mix (lagoon)	bank-buried floating cover	20 days	18 days (estimate)
Baldwin Dairy	combined	psychrophilic	covered lagoon	bank-buried floating cover	6-7 months	not available
Bell Farms	combined	mesophilic	complete mix	flexible	20 days	35 days (estimate)
Emerald Dairy	combined	psychrophilic	covered lagoon	bank-buried floating cover	not available	not available
Fairgrove Farms	combined	mesophilic	plug flow	fixed	18 days on average	20-21 days
Gordondale Farms	combined	mesophilic	plug flow loop	fixed	HRT 20 days, SRT 25-30 days	20 days
Haubenschild Farms	combined	mesophilic	plug flow	flexible	20 days	21 days
Maple Leaf Farms	combined	mesophilic	complete mix	fixed	not available	5 days

\* The target operating temperature for the Crawford Farm digester (86°F) is below the range defined as "mesophilic" in Lusk, 1998, but falls within the mesophilic range as defined by the German Biogas Association and that defined by IEA Bioenergy. The designer defines the digester as mesophilic.

Digester Information Subset (continued)

Farm Name	Solids Separation	Separator Type	Design Temp.	RAS	Digester Designer
<b>CONSTRUCTION</b>					
Herrema Dairy	planned	not available	100°F	yes	GHD, Inc.
New Horizons Dairy	planned	post digestion	100°F	no	RCM Digesters, Inc.
Northern Plains Dairy	yes	Fayn or Vincent screw press, post digestion	100°F	no	RCM Digesters, Inc.
<b>STARTUP</b>					
Crawford Farm	settling tank (sized to batch) after digester	not applicable	86°F	yes	Shih Wu Sung and Fox Engineering
Double S Dairy	yes	screw press, post digestion	100°F	yes	GHD, Inc.
Futura Dairy	yes	Vincent screw press separator, post digestion	100°F	yes	GHD, Inc.
Northeast IA CC Farm	yes	Vincent screw press 6" dia before digester	98°F	potential	Dan Meyer
Stencil Farm	yes	Fayn brand screw press, post digestion	100°F	no	RCM Digesters, Inc.
Tinedale Farms	planned	not an agricultural type separator, post digestion	95-100° and 130°F	no	Ag Environmental Solutions, LLC, and STS Consultants, Ltd.
Top Deck Holsteins	planned	post-digestion	98°F	potential	Dan Meyer and AGRIN, LLC
Wholesome Dairy	yes	auger type squeeze separator, post digestion	100°F	yes	GHD, Inc.
<b>OPERATIONAL</b>					
Apex Pork	no	not applicable	not available	no	RCM Digesters, Inc.
Baldwin Dairy	no	not applicable	ambient	no	Tiry Engineering
Bell Farms	no	considering using before digestion to reduce liquid	not available	no	RCM Digesters, Inc.
Emerald Dairy	no	not applicable	ambient	no	Tiry Engineering
Fairgrove Farms	yes	Vincent screw press, post digestion	not available	no	AGRIN, LLC, and Perennial Energy
Gordondale Farms	yes	screw press post digestion	100°F	yes	GHD, Inc.
Haubenschild Farms	no	not applicable	100°F	no	RCM Digesters, Inc.
Maple Leaf Farms	yes	internally fed rotary drum screen prior to digestion	not available	yes	Applied Technologies, Inc.

## Digester Outputs Subset

Farm Name	Biogas in CFD	Methane Content	Prime Mover <sup>a</sup>	Electricity Output <sup>b</sup>
<b>CONSTRUCTION</b>				
Herrema Dairy	not available	not available	350kW Hess engine generator (x2)	4.56 million kWh/year, (predicted) or 550kW avg. output
New Horizons Dairy	140,000-170,000 predicted	60% (predicted)	150kW Caterpillar 3406 engine generator set (x2) (135kW for biogas) induction generator	1,766,000 kWh/yr (predicted – net of on-farm use)
Northern Plains Dairy	140,000 –160,000 predicted	60% (predicted)	160kW Caterpillar 3406T engine generator set (x2) (140kW for biogas)	2.3 million kWh/yr (predicted) or 280kW avg. output
<b>STARTUP</b>				
Crawford Farm	was 40,000-45,000 in '99, now in startup	not available (was 74% in '99)	undisclosed boiler	not applicable
Double S Dairy	not available	54-60%	200kW Hess engine generator set	1.2M - 1.6M kWh/yr @1000 cows (predicted)
Futura Dairy	not available	not available	140kW Hess engine generator set (synchronous)	not available
Northeast IA CC Farm	4,600	not available	undisclosed	not available
Stencil Farm	72,000	60%	140kW Caterpillar engine generator set	not available
Tinedale Farms	expect 288,000, now 158,000	was 65%, expect as high as 75%	375kW Waukesha engine generator set (x2)	not available
Top Deck Holsteins	52,000	63%	100kW Waukesha, 30kW Capstone microturbine	832,000 kWh/yr (predicted)
Wholesome Dairy	not available	52-56%	508kW Deutz engine generator set (synchronous)	4.1 million kWh/yr (predicted) or 500 kW avg. output
<b>OPERATIONAL</b>				
Apex Pork	36,000 mid summer '98	not available	Burnham boiler	not applicable
Baldwin Dairy	not available	60% summer, 40% winter	not applicable	not applicable
Bell Farms	32,000	65%	80kW Caterpillar 3306 engine generator set (70kW for biogas)	390,000 kWh/year
Emerald Dairy	not available	60% summer, 40% winter	not applicable	not applicable
Fairgrove Farms	57,000 (down recently to 43,000)	62% (down recently to 60%)	85kW Caterpillar engine generator set (70kW for biogas)	480,000 kWh/year
Gordondale Farms	not available	62-64%	150kW Caterpillar 3406 engine generator set (135kW for biogas)	1.12 mil kWh/yr (predicted) or 135kW avg. output
Haubenschild Farms	72,000	62%	150kW Caterpillar 3406 engine generator set (135kW for biogas)	~3000 kWh/day (owner adds <1gal/day of propane to engine)
Maple Leaf Farms	65,000	70%	200kW Hess engine generator set	1.66 million kWh/year (predicted) or ~200kw avg. output

a. Some engine generator sets (as noted) have been specially rated for biogas. Equipment ratings are listed as they were reported in the interviews.

b. When annual output was not supplied by those surveyed, it was estimated based on production rate and 95% uptime.

Cost Information Subset

Farm Name	Digester Cost	Energy Equipment Cost	Total Cost	Utility Contract
<b>CONSTRUCTION</b>				
Herrema Dairy	not available	not available	not available	Not yet, will probably sell all
New Horizons Dairy	not available	not available	\$1,000,000 (estimate)	Not yet
Northern Plains Dairy	not available	not available	\$1,500,000 (estimate)	Not yet
<b>STARTUP</b>				
Crawford Farm	\$165,000	\$45,500	\$290,000	Not applicable
Double S Dairy	\$500,000 (predicted total)	utility owns – cost undisclosed	\$500,000 (digester alone)	Not yet. Will have gas meters on each system, (engine and flare); Alliant Energy will purchase gas.
Futura Dairy	\$104,000	\$163,000	\$307,000 (includes \$40k in unexpected additional costs)	No. Utility does not provide power to the farm.
Northeast IA CC Farm	\$155,000	\$40,000	\$225,000 (includes 30k in unexpected costs)	Not applicable
Stencil Farm	not available	not available	\$400,000 (estimate)	Yes. Have interconnection contract with Wisconsin Public Service, sell at tariffed rate, use for farm first, do net metering.
Tinedale Farms	not available	not available	not available	Contract with WE Energy, all electricity sold to the utility.
Top Deck Holsteins	\$140,000	\$200,000	\$400,000 (includes \$60,000 in unexpected costs)	Yes. Alliant pays farm on a scaled rate structure, no net metering, no time of day rate now.
Wholesome Dairy	not available	not available	\$1.3 million	Yes. Have a sell all agreement with Wisconsin Public Service. Rate undisclosed. Rate includes adder for renewable energy credits.
<b>OPERATIONAL</b>				
Apex Pork	\$66,700	not available	\$152,300 (total cost for system including changes)	Not applicable
Baldwin Dairy	\$70,000	not applicable	\$70,000 (includes only cover and gas collection equipment)	Not applicable
Bell Farms	not available	not available	\$576,000 (1/2 covered by Iowa and Fed funding)	Yes. Contract with rural electric cooperative
Emerald Dairy	\$125,000	not applicable	\$125,000 (includes only cover and gas collection equipment)	Not applicable
Fairgrove Farms	\$150,000 (1981 dollars, \$284,000 in 2000 dollars)	\$50,000 (1981 dollars, \$96,000 in 2000 dollars)	\$200,000 (in 1981 dollars, \$380,000 in 2000 dollars)	Yes. Sell to utility at \$.03/kW (they pay \$.10/kW)
Gordondale Farms	between \$280,000 and \$300,000	\$230,000	\$520,000 total	Yes. Utility purchases gas based on kWh produced.
Haubenschild Farms	\$125,100	\$157,500	\$355,000 (includes \$40,000 in-kind services from AgSTAR, extra wiring and plumbing, and some other unexpected costs)	Yes. Contract with East Central Energy Cooperative, power purchase 7.25 cents/kWh, same rate for elec. used on farm. Changed to 7.3 in 2001.
Maple Leaf Farms	\$350,000 (in 1988 dollars, \$509,000 in 2000 dollars)	\$270,000 (purchased in 2002)	\$779,000	Yes. Have 2 year contract with WE Energies, sell all to utility, \$0.05/kWh premium (net).

## Digester History Subset

Farm Name	Construction Period	Startup Period	Date Operational
<b>CONSTRUCTION</b>			
Herrema Dairy	March 2002, start populating July 2002	August 2002 (predicted)	Not applicable
New Horizons Dairy	October 2001 – August 2002	not applicable	Not applicable
Northern Plains Dairy	May 2002 – September 2002	not available	Not applicable
<b>STARTUP</b>			
Crawford Farm	Summer 1998 to Fall 1998	December 1998 to May 1999	stabilized May 1999, now off line awaiting part
Double S Dairy	built dairy and digester at same time, Oct '01-Feb '02	May 2002, started engine running on biogas, started manure feed in March 2002	Not applicable
Futura Dairy	new dairy, April 2001 – September 2001	not available	Not applicable
Northeast IA CC Farm	August '00 - Oct. '00 digester, boiler added March '01	April 2001 first time, ran 3-4 months, second April 2002	Not applicable
Stencil Farm	June 01-Jan 02, farmer was general contractor	Began January 2002	Not applicable
Tinedale Farms	2 periods, some idle time	June – September 2001, switched to TPAD, October – December 2001, then meso-meso again	predicted going to TPAD in July 2002
Top Deck Holsteins	October 2000- March 2002, part of dairy expansion	March 2002	summer 2002 (expected)
Wholesome Dairy	Spring 2001 for 9 months	Began end of April 2002	Not applicable
<b>OPERATIONAL</b>			
Apex Pork	took about 3 months, did most themselves, heater is 3" black steel pipe	1st, summer 1998, second December 28, 1998	first, June 1998, second January 1999
Baldwin Dairy	1998	not applicable	1998
Bell Farms	1998	June 1999 - August 1999, new farm took a while to populate with pigs	September 1999
Emerald Dairy	1999	not applicable	1999
Fairgrove Farms	October 1980 (estimate)	original 1 month, same after each clean-out	January 1981
Gordondale Farms	Oct. 2000-Nov 2001, owner did it himself	Started adding manure November 2001 – April 2002	April 2002
Haubenschild Farms	March 1999 to July 1999	July 1999 started warming manure - September 1999	September 1999
Maple Leaf Farms	Built in 1988, about 3 months	1st time 6 months., after clean-out for 2nd try up in 1 month.	1988



## **APPENDIX A: REFERENCES**

Al Seadi, Teodorita, *Good Practice in Quality Management of AD Residues from Biogas Production*, Task 24, Energy from Biological Conversion of Organic Waste, IEA Bioenergy, University of Southern Denmark, Esbjerg, Denmark, no date.

Burke, Dennis A., *Dairy Waste Anaerobic Digestion Handbook: Options for Recovering Beneficial Products from Dairy Manure*, Environmental Energy Company, June 2001

Ciborowski, Peter, *Anaerobic Digestion of Livestock Manure for Pollution Control and Energy Production: A Feasibility Assessment*, Minnesota Pollution Control Agency, March 2001.

da Costa Gomez, Claudius, "State-of-Art and Future Development in German Biogas," Secretary General, German Biogas Association, Freising, Germany, no date.

Lusk, Phil, *Methane Recovery from Animal Manures: The Current Opportunities Casebook*, National Renewable Energy Laboratory, 1998. Available from the NREL Web site <http://www.nrel.gov/publications/>.

Midwest Energy Research Center, *Turning Manure Into Gold: Converting Agricultural Waste to Energy*, prepared for the Ohio Biomass Energy Program, Columbus, OH, 2000. This publication can be downloaded from the following URL: [www.opaemerc.org/biomass.pdf](http://www.opaemerc.org/biomass.pdf), or ordered in print form from the following site <http://www.theoec.org>.

Nelson, Carl, and John Lamb, *Final Report: Haubenschild Farms Anaerobic Digester*, December 2000, The Minnesota Project.

Nelson, Carl, and John Lamb, *Final Report: Haubenschild Farms Anaerobic Digester – Updated*, August 2002, The Minnesota Project.

Parsons S A, Wall F, Doyle J, Oldring K and Churchley J, "Assessing the Potential for Struvite Recovery at Sewage Treatment Works," School of Water Sciences, Cranfield University, Cranfield, Bedfordshire, U.K., Severn Trent Water Ltd, Avon House, St Martins Road, Coventry, U.K., no date.

Rodzilsky, Jack L., *A Case Study of Michigan Farm-Based Anaerobic Digestion: Suggestions for Successful Farm-Based Bioenergy Systems*, Michigan State University, presented at BioEnergy '98: Expanding BioEnergy Partnerships, in Madison, Wisconsin, USA, October 4-8, 1998.

Roos, K.F., and M.A. Moser (ed.s), *AgSTAR Handbook A Manual for Developing Biogas Systems at Commercial Farms in the United States*, United States Environmental Protection Agency, Document No. EPA-430-B-97-015, July, 1997.

Warburton, Diane, ed., *Anaerobic Digestion of Farm and Food Residues: Good Practice Guidelines*, The Environmental Council, London, England, no date.

Weiland, Peter, "Process, Technique and Typical Application of Biogas Technology in Germany," presented at Biogas International 2002, Berlin, Germany, January 17-19, 2002.

## ***APPENDIX B: SAMPLE OF WEB-BASED RESOURCES***

ADNet European and Canadian resource site

<http://www.ad-nett.org>.

Canadian ManureNet Web site

[http://res2.agr.ca/initiatives/manurenet/manurenet\\_en.html](http://res2.agr.ca/initiatives/manurenet/manurenet_en.html)

German Biogas Association home page

<http://www.biogas.org/english/frame1.html>

U.S. Environmental Protection Agency's AgSTAR site

<http://www.epa.gov/agstar/>

## APPENDIX C: STATE FUNDING SOURCES OR OTHER INCENTIVES FOR AGRICULTURAL BIOGAS PROJECTS

### RESIDENTS OF ALL GREAT LAKES STATES ARE ELIGIBLE FOR:

AgSTAR		Great Lakes Regional Biomass Energy Program	
Contact person	Funding specifics	Contact person	Funding specifics
(800) 95-AgSTAR <a href="http://www.epa.gov/outreach/agstar/index.htm">http://www.epa.gov/outreach/agstar/index.htm</a>	Directed to show dairy and pork producers "how to manage manure profitably while protecting the environment."	Fred Kuzel, Director 35 East Wacker Drive, Suite 1850 Chicago, IL 60601 Phone: (312) 407-0177 Fax: (312) 407-0038 fkuzel@cglg.org <a href="http://www.cglg.org/projects/biomass/index.html">http://www.cglg.org/projects/biomass/index.html</a>	Targeted projects include the area of liquid biofuels and biomass power.
Funding amount	Application	Funding amount	Application
Contact AgSTAR for more information.	Contact AgSTAR for more information.	In 2001, the maximum award was \$40,000, with a minimum 1:1 match in funds.	Solicitations are due in the spring.
Rural Business Opportunity Grants - USDA Rural Business Cooperative Program		U.S. Department of Energy's Regional Biomass Energy Program	
Contact person	Funding specifics	Contact person	Funding specifics
<a href="http://www.rurdev.usda.gov/rbs/busp/bpdir.htm">http://www.rurdev.usda.gov/rbs/busp/bpdir.htm</a>	USDA seeks to assist entities in rural areas to obtain loans for the purpose of improving the economic and environmental climate in rural communities, including initiatives for pollution abatement and control.	Doug Kaempf (202) 586-5264 <a href="http://www.ott.doe.gov/rbep">http://www.ott.doe.gov/rbep</a>	Cost sharing for a wide range of biomass projects, including agricultural biogas systems.
Funding amount	Application	Funding amount	Application
Loans ranging from \$35,000 to \$10 million for a total of \$50 million.	Contact the USDA Rural Business Cooperative Program for more information.	Contact the U.S. Department of Energy for more information.	Contact the U.S. Department of Energy for more information.
US Department of Agriculture - Rural Development		USDA Environmental Quality Incentives Program	
Contact person	Funding specifics	Contact person	Funding specifics
James T. Cogan Federal Building, Room 507 200 North High Street Columbus, OH 53215 (614) 255-2420; <a href="http://www.rurdev.usda.gov">http://www.rurdev.usda.gov</a> or <a href="http://www.rurdev.usda.gov/oh/index.html">http://www.rurdev.usda.gov/oh/index.html</a> For a contact person in your area, go to <a href="http://offices.usda.gov/scripts/nrlSAPI.dll/oip_public/USA_map">http://offices.usda.gov/scripts/nrlSAPI.dll/oip_public/USA_map</a> and click on your state, then county.	Many different loans are available. Ask which loans you might qualify for.	Anthony Esser (202) 720-1840 anthony.esser@usda.gov <a href="http://www.nrcs.usda.gov/programs/eqip/">http://www.nrcs.usda.gov/programs/eqip/</a>	The Environmental Quality Incentives Program (EQIP) provides technical and financial assistance to eligible farmers and ranchers to address soil, water, and related natural resource concerns on their lands in an environmentally beneficial manner. Contracts of up to 10 years are made with eligible producers. Cost-share payments may be made to implement one or more eligible conservation practices, such as animal waste management facilities, terraces, filter strips, tree planting, and permanent wildlife habitat. Incentive payments can be made to implement one or more land management practices, such as nutrient management, pest management, and grazing land management. Sixty percent of the funding available for the program will be targeted at practices relating to livestock production.
Funding amount	Application	Funding amount	Application
Contact James Cogan for more information.	Contact James Cogan for more information.	Contact Anthony Esser for more information.	Contact Anthony Esser for more information.

**RESIDENTS OF MANY OF THE GREAT LAKES STATES (SEE FUNDING SPECIFICS) ARE ELIGIBLE FOR:**

Renewable Development Fund - Xcel Energy		The Ohio Energy Efficiency Revolving Loan Fund	
Contact person	Funding specifics	Contact person	Funding specifics
Debra Paulson, Case Specialists, Regulatory Administration (612) 904-5366	Preference is given to proposals that include: promoting economic growth in Minnesota, providing additional value by leveraging requested RDF funds with other sources, and others listed in the Request for Proposal. Follow up research and/or questions may be required. Priority is given to: 1) Minnesota farms in Xcel Energy's service territory, 2) located in Minnesota, 3) located within Xcel Energy's service territory in ND, SD, WI or MI.	Judy Jones (614) 466-8139 jsjones@odod.state.oh.us	Individuals or businesses within the territories of the following utilities are eligible to apply for a loan: First Energy, American Electric Power, Dayton Power and Light, Cinergy (Cincinnati Gas and Electric) and Monongahela Power (Allegheny Power)
Funding amount	Application	Funding amount	Application
The seven grants awarded to biomass projects in 2001 ranged from \$60,000 to \$1,250,142.	"Target Schedule" - Applicants responded to an annual "Request for Proposal" sent out in July by Xcel. Xcel forwarded their final selections to MN Public Utilities Commission in November for final approval. Individuals may also apply if funding is for experimentation or research (select category B or C on the application).	Low interest loan - Approximately \$15 million awarded per year.	Contact Judy Jones for more information.

**RESIDENTS OF IOWA ARE ELIGIBLE FOR:**

Alternate Energy Revolving Loan Program - Iowa Energy Center		IOWA - Environmental Protection Agency - Office of Wastewater Management "The Clean Water State Revolving Fund Program"	
Contact person	Funding specifics	Contact person	Funding specifics
Keith Kutz Iowa Energy Center 2521 Elwood Drive, Suite 124 Ames, IA 50010-8263 (515) 294-8819 <a href="http://www.energy.iastate.edu/AE_RLP/loans.html">http://www.energy.iastate.edu/AE_RLP/loans.html</a>	The program provides low-interest loans to individuals and organizations who wish to build alternative energy production facilities in Iowa.	Jeffrey R. Vonk, Director Department of Natural Resources 502 E. Ninth Street Des Moines, IA 50319-0034 Phone: (515) 281-5385 Fax: (515) 281-6794 jeff.vonk@dnr.state.ia.us <a href="http://www.epa.gov/owm/finan.htm">http://www.epa.gov/owm/finan.htm</a>	Previously the Construction Grants Program, this new, more flexible program, with control at the state level, has a wide variety of options, including funding of agriculture best management practices, and manure management and disposal.
Funding amount	Application	Funding amount	Application
Low-interest loans for 50% of the total loan, up to a maximum of \$250,000 will be awarded. Zero percent interest loan for half of financing costs associated with project.	Application deadlines: October 31 and March 31 of each year.	Low interest loans, or other options such as: refinancing, purchasing, or guaranteeing local debt, and purchasing bond insurance.	Contact Jeffrey Vonk for more information.

Iowa Dept. of Natural Resources		Iowa Dept. of Natural Resources	
<b>Contact person</b>	<b>Funding specifics</b>	<b>Contact person</b>	<b>Funding specifics</b>
David Downing (515) 281-4876 david.downing@dnr.state.ia.us	Methane Gas Conversion Property Tax Exemption Eligible technologies include alternative fuels.	David Downing (515) 281-4876 david.downing@dnr.state.ia.us	Methane Energy Replacement Generation Tax Exemption. This statute exempts electricity generated by methane gas conversion property from the replacement generation tax, which is six hundredths of a cent per kilowatt-hour.
<b>Funding amount</b>	<b>Application</b>	<b>Funding amount</b>	<b>Application</b>
Loan amount - 100% of the project.	Applications shall be filed with the assessing authority not later than February 1 of each year for which the exemption is requested on forms provided by the Department of Revenue and Finance.	Six hundredths of a cent per kWh	Contact David Downing for more information.
Iowa Energy Center		Solid Waste Alternatives Programs (SWAP)	
<b>Contact person</b>	<b>Funding specifics</b>	<b>Contact person</b>	<b>Funding specifics</b>
Keith Kutz Iowa Energy Center 2521 Elwood, Suite 124 Ames, IA 50010-8263 515-294-8819 <a href="http://www.energy.iastate.edu/">http://www.energy.iastate.edu/</a>	Contact Keith Kutz for more information.	Valerie Drew Iowa DNR - Waste Management Assistance Division (515) 281-8672 valerie.drew@dnr.state.ia.us <a href="http://www.state.ia.us/dnr/organization/wmad/wmabureau/solidwaste/swap/index.htm">http://www.state.ia.us/dnr/organization/wmad/wmabureau/solidwaste/swap/index.htm</a>	The Solid Waste Alternatives Program (SWAP) funds the statewide development and expansion of waste reduction and recycling projects.
<b>Funding amount</b>	<b>Application</b>	<b>Funding amount</b>	<b>Application</b>
varies	Contact Keith Kutz for more information.	First \$20,000 is in the form of a forgivable loan, the next \$150,000 is a zero-percent interest loan, anything more than \$170,000 is a 3 percent interest loan.	Pre-proposals are accepted year round and reviewed quarterly.
Value-Added Agricultural Products and Processes Financial Assistance Program (VAAPFAP) - Iowa Renewable Fuel Fund			
<b>Contact person</b>	<b>Funding specifics</b>		
Joe Jones Iowa Department of Economic Development - Bureau of Business Finance (515) 242-4801 <a href="http://www.smart.state.ia.us/financial.htm#vaapfap">http://www.smart.state.ia.us/financial.htm#vaapfap</a>	The State Loan Program offers a combination of forgivable and traditional loans, with the interest rate typically the prime rate. Research and development projects are not eligible for this program.		
<b>Funding amount</b>	<b>Application</b>		
Combination of forgivable and traditional loans, with a maximum of \$525,000.	Contact Joe Jones for more information.		

## RESIDENTS OF ILLINOIS ARE ELIGIBLE FOR:

ILLINOIS - Environmental Protection Agency - Office of Wastewater Management "The Clean Water State Revolving Fund Program"		Illinois Department of Commerce and Community Affairs - Renewable Energy Resources Program	
Contact person	Funding specifics	Contact person	Funding specifics
Renee Cipriano, Director Environmental Protection Agency P.O. Box 19276 Springfield, IL 62794-9276 Phone: (217) 782-3397 Fax: (217) 782-9039 renee.cipriano@epa.state.il.us http://www.epa.gov/owm/finan.htm	Previously the Construction Grants Program, this new, more flexible program, with control at the state level, has a wide variety of options, including funding of agriculture best management practices, and manure management and disposal.	Rex Buhrmester Illinois Department of Commerce and Community Affairs; Bureau of Energy and Recycling; Alternative Energy Development Section RERP 620 East Adams Street Springfield, IL 62701 (217) 557-1925 (TDD 800/785-6055) http://www.commerce.state.il.us/resource_efficiency/energy/rep.html	Provides rebate and grant funding for projects that increase the use of alternative energy technologies. Funding for new organic waste biomass systems that have successfully completed at least one year of field testing. The system must be designed to produce an/or use biogas as a source of fuel to produce electricity or heat. System and size design will be evaluated by the Department on a case by case basis. The farmer is required to allow the Department access to the project site and the ability to obtain, publish, disseminate or distribute any and all information obtained from the project (except information that has been negotiated as being confidential or proprietary) for at least one year from the commencement date. Funds may be used only for the purchase of equipment and installation expenses - see application for more specifics.
Funding amount	Application	Funding amount	Application
Low interest loans, or other options such as; refinancing, purchasing, or guaranteeing local debt, and purchasing bond insurance.	Contact Renee Cipriano for more information.	Organic Waste Biomass (electrical production) - 50 percent with a maximum grant of \$550,000; Organic Waste Biomass (heat production) - 50 percent with a maximum of \$350,000.	Request and fill in the department's current approved forms. Applications will be accepted on an ongoing basis with grants awarded July 1 through June 30 of each state fiscal year.
Renewable Energy Resources Program - IL Dept of Commerce and Community Affairs - Bureau of Energy and Recycling			
Contact person	Funding specifics		
David Loos IL Dept. of Commerce and Community Affairs; Bureau of Energy and Recycling 325 West Adams, Room 300 Springfield, IL 62704-1892 Phone: (217) 785-3969 Fax (217) 785-2618 dloos@commerce.state.il.us http://www.ies.ncsu.edu/dsire/library/includes/incentive2.cfm?Incentive_Code=IL02F&state=IL&currentpageID=1;	This grant program funds capital projects of any renewable energy technology.		
Funding amount	Application		
\$60,000 to \$1,000,000 grants will be awarded, with appropriations of \$5 million.	Contact David Loos for more information.		

## RESIDENTS OF INDIANA ARE ELIGIBLE FOR:

Alternative Power and Energy Grant Program - Indiana Department of Commerce Energy Policy Division		INDIANA - Environmental Protection Agency - Office of Wastewater Management "The Clean Water State Revolving Fund Program"	
<b>Contact person</b>	<b>Funding specifics</b>	<b>Contact person</b>	<b>Funding specifics</b>
Philip Powlick Indiana Department of Commerce; Energy Policy Division One North Capitol, #700 Indianapolis, IN 46204-2248 Phone: (317) 232-8970 Fax (317) 232-8995 <a href="http://www.state.in.us/doc/energy/transportation.html">http://www.state.in.us/doc/energy/transportation.html</a>	This program is designed to enable businesses and institutions to install and study alternative and renewable energy system applications in areas such as power generation, heating, and waste-to-energy.	Lori Kaplan, Commissioner Department of Environmental Management P.O. Box 6015 Indianapolis, IN 46206-6015 Phone: (317) 232-8603 Fax: (317) 233-6647 lkaplan@dem.state.in.us <a href="http://www.epa.gov/owm/finan.htm">http://www.epa.gov/owm/finan.htm</a>	Previously the Construction Grants Program, this new, more flexible program, with control at the state level, has a wide variety of options, including funding of agriculture best management practices, and manure management and disposal.
<b>Funding amount</b>	<b>Application</b>	<b>Funding amount</b>	<b>Application</b>
Grants range in size from \$5,000 to \$30,000 while grantees are required to provide at least 20% of the equipment costs.	Rolling applications.	Low interest loans, or other options such as; refinancing, purchasing, or guaranteeing local debt, and purchasing bond insurance.	Contact Lori Kaplan for more information.

## RESIDENTS OF MICHIGAN ARE ELIGIBLE FOR:

Michigan biomass Energy Program (MBEP)		MICHIGAN - Environmental Protection Agency - Office of Wastewater Management "The Clean Water State Revolving Fund Program"	
<b>Contact person</b>	<b>Funding specifics</b>	<b>Contact person</b>	<b>Funding specifics</b>
Kelly Launder Energy Office Michigan Dept. of Consumer & Industry Services 6545 Mercantile Way, Suite #9 Lansing, MI 48911 Phone: (517) 241-6223, Fax: (517) 241-6229 E-mail: klaund@michigan.gov	The MBEP provides funding for state bioenergy/biofuel projects on an annual basis.	Russell J. Harding, Director Department of Environmental Quality P.O. Box 30457 - Town Center Lansing, MI 48909-7957 Phone: (517) 373-7917 Fax: (517) 241-7401 hardingr@state.mi.us <a href="http://www.epa.gov/owm/finan.htm">http://www.epa.gov/owm/finan.htm</a>	Previously the Construction Grants Program, this new, more flexible program, with control at the state level, has a wide variety of options, including funding of agriculture best management practices, and manure management and disposal.
<b>Funding amount</b>	<b>Application</b>	<b>Funding amount</b>	<b>Application</b>
Contact Kelly Launder for more information.	Contact Kelly Launder for more information.	Low interest loans, or other options such as; refinancing, purchasing, or guaranteeing local debt, and purchasing bond insurance.	Contact Russell Harding for more information.

Michigan Public Service Commission Low-income and Energy Efficiency Fund			
<b>Contact person</b>	<b>Funding specifics</b>		
Michel Heiser Director of the Competitive Energy Division 517-241-6160	Requests for proposal posted regularly - next posting expected March/April 2003.		
<b>Funding amount</b>	<b>Application</b>		



<p>Up to \$60,000,000 will be made available annually from this fund for six years. In July, 2002, \$12.2 million was awarded to projects, which "develop or improve energy efficient technologies, including those advancing the use of alternative fuels; increase the development of emerging technologies; increase the availability, distribution and market share of various energy technologies; and demonstrate the application of these technologies."</p>	<p>Contact Michel Heiser for details</p>	
---	--	--

## RESIDENTS OF MINNESOTA ARE ELIGIBLE FOR:

<p>MINNESOTA - Environmental Protection Agency - Office of Wastewater Management "The Clean Water State Revolving Fund Program"</p>		<p>Wind Energy (and Manure Methane) Energy Generation Grants July 1999 to June 2005 - Minnesota Department of Commerce</p>	
<p><b>Contact person</b> Terry Kuhlman, Executive Director Public Facilities Authority 500 Metro Square, 121 7th Place East Saint Paul, MN 55101-2146 Phone: (651) 296-4704 Fax: (651) 296-5287 terry.kuhlman@state.mn.us <a href="http://www.epa.gov/owm/finan.htm">http://www.epa.gov/owm/finan.htm</a></p>	<p><b>Funding specifics</b> Previously the Construction Grants Program, this new, more flexible program, with control at the state level, has a wide variety of options, including funding of agriculture best management practices, and manure management and disposal.</p>	<p><b>Contact person</b> Rory Artig Minnesota Department of Commerce; Energy Division 85 E. 7th Place, Suite 500 St. Paul, MN 55101-2198 Phone: (651) 297-2326 Fax (651) 297-7891 rory.artig@state.mn.us <a href="http://www.ies.ncsu.edu/dsire/library/includes/incentive2.cfm?Incentive_Code=MN06F&amp;state=MN&amp;CurrentPageID=1">http://www.ies.ncsu.edu/dsire/library/includes/incentive2.cfm?Incentive_Code=MN06F&amp;state=MN&amp;CurrentPageID=1</a></p>	<p><b>Funding specifics</b> The program offers a direct per kilowatt hour payments for electricity generated from new wind energy projects. Certain hydroelectric facilities and anaerobic manure methane digesters also qualify for payments.</p>
<p><b>Funding amount</b> Low interest loans, or other options such as; refinancing, purchasing, or guaranteeing local debt, and purchasing bond insurance.</p>	<p><b>Application</b> Contact Terry Kuhlman for more information.</p>	<p><b>Funding amount</b> Minnesota will offer a 1.5 cent per kilowatt hour payment for electricity generated from new wind energy projects less than 2 MW in capacity. Qualifying projects will receive payments for ten years.</p>	<p><b>Application</b> Rolling applications.</p>

## RESIDENTS OF OHIO ARE ELIGIBLE FOR:

OHIO - Environmental Protection Agency - Division of Environmental and Financial Assistance "Water Pollution Control Loan Fund"		Ohio Air Quality Development Authority	
<b>Contact person</b>	<b>Funding specifics</b>	<b>Contact person</b>	<b>Funding specifics</b>
Gregory H. Smith, Division Chief Ohio EPA, Division of Environmental and Financial Assistance P.O. Box 1049 122 South Front Street Columbus, OH 43216-1049 Phone: (614) 644-2798 Fax: (614) 644-3687 greg.smith@epa.state.oh.us <a href="http://www.epa.state.oh.us/default/efamain.html">http://www.epa.state.oh.us/default/efamain.html</a>	Assistance to a wide variety of actions, which benefit groundwater or surface water, including storm water runoff control, agricultural best management practices, manure management and disposal, and pollution prevention. Financial assistance can be integrated with other funders. Offering coordination of permits and approvals and applications.	Mark Shanahan or Mike Suver (800) 225-5051 mark.shanahan@aqda.state.oh.us <a href="http://www.ohioairquality.org/">http://www.ohioairquality.org/</a>	Financing, tax incentives, and/or grants to cover closing costs of financing pollution control projects.
<b>Funding amount</b>	<b>Application</b>	<b>Funding amount</b>	<b>Application</b>
Low interest direct loans, interest rate buy-down from private lenders, credit enhancements. No maximum loan amount. Eligible costs for planning, design, and construction may be funded.	Annual funding cycle; applications accepted at any time. Please contact Greg Smith for details.	Contact Mark Shanahan for more information.	Contact Mark Shanahan for more information.
Ohio Biomass Energy Program			
<b>Contact person</b>	<b>Funding specifics</b>		
Anne Goodge, Program Director Ohio Biomass Energy Program; Public Utilities Commission of Ohio 180 East Broad Street Columbus, Ohio 43215-3793 Phone: (614) 644-7857 Anne.Goodge@puc.state.oh.us <a href="http://www.puc.state.oh.us/ohiouti/biomass/biomass.html">http://www.puc.state.oh.us/ohiouti/biomass/biomass.html</a>	Grant funding available on occasional basis. Contact Anne Goodge or see the Web site under "Biomass Grants and Assistance".		
<b>Funding amount</b>	<b>Application</b>		
Contact Anne Goodge or see the Web site under "Biomass Grants and Assistance".	Contact Anne Goodge or see the Web site under "Biomass Grants and Assistance".		

## RESIDENTS OF WISCONSIN ARE ELIGIBLE FOR:

Public Benefits Fund - Wisconsin Energy Bureau		Renewable Energy Assistance Program (REAP) - Wisconsin Department of Administration	
<b>Contact person</b>	<b>Funding specifics</b>	<b>Contact person</b>	<b>Funding specifics</b>
Alex DePillis Wisconsin Energy Bureau; Division of Energy & Public Benefits PO Box 7868 Madison, WI 53707-7868 Phone: (608) 266-1067 Fax (608) 267-6931 alex.depillis@doa.state.wi.us <a href="http://www.doa.state.wi.us/depb/b">http://www.doa.state.wi.us/depb/b</a>	Financial assistance to low income programs and energy efficiency and renewable energy services.	Alex DePillis Wisconsin Energy Bureau; Division of Energy & Public Benefits PO Box 7868 Madison, WI 53707-7868 Phone: (608) 266-1067 Fax (608) 267-6931 alex.depillis@doa.state.wi.us <a href="http://www.doa.state.wi.us/depb/bo">http://www.doa.state.wi.us/depb/bo</a>	Program provides grant funds for renewable energy systems incorporated into construction projects. All renewable energy technologies are eligible for these grants, although the focus of the projects funded are wood/biogas and hydropower energy projects.

oe		e	
<b>Funding amount</b>	<b>Application</b>	<b>Funding amount</b>	<b>Application</b>
Annual finding is roughly \$84 million, with at least \$3.8 million going toward renewables projects.	Funding to be continued through 2005.	Construction grants fund 10-20% of a project up to \$75,000 and are performance based, whereby half of the grant is available on equipment purchase and the other half is available upon project completion.	No application deadline.
Waste Reduction and Recycling - Wisconsin DNR Bureau of Community Financial Assistance		WISCONSIN - Environmental Protection Agency - Office of Wastewater Management "The Clean Water State Revolving Fund Program"	
<b>Contact person</b>	<b>Funding specifics</b>	<b>Contact person</b>	<b>Funding specifics</b>
Sheila Henneger Wisconsin Department of Natural Resources, Bureau of Community Financial Assistance PO Box 7921 Madison, WI 53707-7921 (608) 266-7555 hennes@dnr.state.wi.us <a href="http://www.dnr.state.wi.us/org/cae/r/cfa/ef/recycle/index.html">http://www.dnr.state.wi.us/org/cae/r/cfa/ef/recycle/index.html</a>	Provide grants for innovative waste reduction and recycling projects on a pilot or demonstration scale.	Kathryn A. Curtner, Director DNR, Bureau of Community Financial Assistance P.O. Box 7921 - CF/8 Madison, WI 53707-7921 Phone: (608) 266-0860 Fax: (608) 267-0496 curtnk@dnr.state.wi.us <a href="http://www.epa.gov/owm/finan.htm">http://www.epa.gov/owm/finan.htm</a>	Previously the Construction Grants Program, this new, more flexible program, with control at the state level, has a wide variety of options, including funding of agriculture best management practices, and manure management and disposal.
<b>Funding amount</b>	<b>Application</b>	<b>Funding amount</b>	<b>Application</b>
\$300,000 in funds available annually for 2001-2002 projects. The maximum grant amount is \$150,000 with 5-10 grants funded per year. Approximately \$500,000 will be available for 2002-2003.	Application deadline is August 1st of each year.	Low interest loans, or other options such as; refinancing, purchasing, or guaranteeing local debt, and purchasing bond insurance.	Contact Kathryn Curtner for more information.

## **APPENDIX D: DIGESTER SYSTEM DESIGNERS AND CONSULTANTS AND EQUIPMENT SUPPLIERS**

Note: This information may help producers begin looking for odor control, waste management and energy conversion vendors and system designers. The presence of any specific company information in this source does not constitute an endorsement of the company or product effectiveness on the part of either McNeil Technologies, Inc. or any office of the State of Colorado or other government entity.

### **Great Lakes Regional Biomass Energy Program STATE BIOMASS COORDINATORS**

#### **GREAT LAKES STATES**

Fred Kuzel  
Director, Great Lakes Regional Biomass Energy Program  
Council of Great Lakes Governors  
35 East Wacker Drive, Suite 1850  
Chicago, IL 60601  
Phone: (312) 407-0177  
Fax: (312) 407-0038  
E-mail: [fkuzel@cglg.org](mailto:fkuzel@cglg.org)  
Web site: <http://www.cglg.org/projects/biomass>

#### **FEDERAL**

Kurt Roos  
AgSTAR Program Director  
Mail Stop 6206-J  
401 M Street, SW  
Washington, DC 50460  
Phone: 202/564-9041  
Fax: 202/564-9569  
E-mail: [roos.kurt@epa.gov](mailto:roos.kurt@epa.gov)  
Web site: [www.epa.gov/methane/agstar](http://www.epa.gov/methane/agstar)

#### **ILLINOIS**

Norm Marek  
Bureau of Energy and Recycling  
Illinois Department of Commerce and Community Affairs  
620 East Adams  
Springfield, IL 62704  
Phone: (217) 785-5082, Fax: (217) 785-2618  
E-mail: [nmarek@commerce.state.il.us](mailto:nmarek@commerce.state.il.us)

#### **INDIANA**

Philip Powlick  
Division of Energy Policy  
Indiana Department of Commerce  
One North Capitol, Suite 700  
Indianapolis, IN 46204  
Phone: (317) 232-8970, Fax: (317) 232-8995  
E-mail: [ppowlick@commerce.state.in.us](mailto:ppowlick@commerce.state.in.us)

#### **IOWA**

Angela Chen, Executive Officer  
Energy Bureau  
Iowa Department of Natural Resources  
Wallace State Office Building  
Des Moines, IA 50319-0034  
Phone: 515-281-4736, Fax: 515-281-6794  
E-mail: [Angela.Chen@dnr.state.ia.us](mailto:Angela.Chen@dnr.state.ia.us)

#### **MICHIGAN**

Kelly Launder  
Energy Office  
Michigan Dept. of Consumer & Industry Services  
6545 Mercantile Way, Suite #9  
Lansing, MI 48911  
Phone: (517) 241-6223, Fax: (517) 241-6229  
E-mail: [klaund@michigan.gov](mailto:klaund@michigan.gov)

#### **MINNESOTA**

Lois Mack  
Minnesota Department of Commerce  
85 7th Place East - Suite 500  
St. Paul, MN 55101-2198  
Phone: 651-296-8900, Fax: 651-296-5819  
E-mail: [lmack@dpsv.state.mn.us](mailto:lmack@dpsv.state.mn.us)

#### **OHIO**

Bibhakar Shakya  
Public Utilities Commission of Ohio  
180 East Broad Street, 6th Floor  
Columbus, OH 43215  
Phone: (614) 466-2094, Fax: (614) 752-8352  
E-Mail: [bibhakar.shakya@puc.state.oh.us](mailto:bibhakar.shakya@puc.state.oh.us)

#### **WISCONSIN**

Alexander F. DePillis  
Wisconsin Department of Administration  
Division of Energy & Public Benefits  
101 East Wilson Street, 6th Floor  
P.O. Box 7868 Madison, WI 53707-7868  
Phone: (608) 266-1067, Fax: (608) 267-6931  
E-mail: [alex.depillis@doa.state.wi.us](mailto:alex.depillis@doa.state.wi.us)

## **ANAEROBIC SYSTEMS**

### **AgriWaste Technology, Inc.**

Mr. Mac Safley, Jr.  
700-108 Blue Ridge Road  
Raleigh, NC 27606  
Phone: 919/829-0014  
Fax: 919/829-1507  
E-mail: agriwaste@aol.com

### **Agway Farm Research Center**

Mr. Stanley Weeks  
6978 New York, Route 80  
Tully, NY 13159  
Phone: 315/683-5700

### **A.O. Smith Harvestore Products, Inc.**

345 Harvestore Drive  
DeKalb, IL 60115  
Phone: 815/756-1561

### **Applied Technologies, Inc.**

Mr. John F. Kouba, P.E.  
Senior Project Manager  
16815 West Wisconsin Avenue  
Brookfield, WI 53005  
Phone: 414/784-7690  
Fax: 414/784-6847  
E-mail: jfkouba@ati-ae.co

### **BioRecycling Technologies, Inc.**

Jim Hamamoto  
6101 Cherry Avenue  
Fontana, CA 92336  
Phone: 909/899-2982  
Fax: 909/899-9519

### **Charles R. Browning & Associates**

Suite 102  
3008 Anderson Drive  
Raleigh, NC 27609  
Phone: 919/782-3432  
Fax: 919/781-7796

### **Commercial Engineering Corp.**

Skip Newton  
2890 Dundee Road  
Northbrook, IL 60062-2052  
Phone: 847/205-1112 x21  
Fax: 847/205-1119

### **Duke Engineering & Services**

Harold L. Backman, PE  
PO Box 1004  
Charlotte, NC 28210-1004  
Phone: 704/382-8570  
Fax: 704/383-6970  
E-mail: hbackma@duke-engineering.com

### **Environmental Treatment Systems, Inc.**

P.O. Box 94005  
Atlanta, GA 30377  
Phone: 770/384-0602

### **ENTEK Biosystems, LC**

Bob Urell  
PO Box 372  
Smithfield, VA 23431-0372  
Phone: 757/365-4155  
Fax: 757/657-6500  
E-mail: entekbio@aol.com

### **Enviroenergy Systems, Inc.**

Paul Serbu  
7860 Woodridge Dreive  
Gainesville, VA 22075  
Phone: 703/754-2042  
Fax: 703/456-0414

### **Environmental Treatment Systems**

Charles Ross, PE  
Suite 100  
1500 Wilson Way  
Smyrna, GA 30082  
Phone: 702/384-0602

### **Environomics, Inc.**

Mr. Richard Mattocks  
36 West 35th Street Suite 5E  
New York, NY 10001  
Phone: 212/564-7188  
e-mail: utter@compuserve.com  
Web site:  
<http://www.waste2profits.com/>

### **Feldmann and Associates**

Terry Feldmann  
11191 Carolyn Court  
East Peoria IL 61611  
Phone: 309/822-9828  
E-mail: tfeldmann@aol.com

### **Fox Engineering Associates, Inc.**

Dale Watson  
1531 Airport Road  
Ames IA 50010  
Phone: 515/233-0000  
Fax: 515/233-0103  
E-mail: dwatson@foxeng.com  
Web site: [www.foxeng.com](http://www.foxeng.com)

### **GHD Inc.**

Steve Dvorak  
P.O. Box 69  
Chilton WI 53014  
Phone: 920/849-9797  
Fax: 920/849-9160  
E-mail: ddghd@tds.net

### **Hadley and Bennett, Inc.**

Spencer Bennett  
P.O. Box 517  
Henniker NH 03242  
Phone: 603/428-3851  
Fax: 603/428-3851  
E-mail:  
[bennettfarm@conknet.com](mailto:bennettfarm@conknet.com)

### **L&J Dairy Services**

Lee Peterson  
319-883-8911

### **Lock Four**

Stacy Gettier  
P.O. Box 474  
Waverly VA 23890  
Phone: 804/834-8317  
Fax: NA  
E-mail: swg@erols.com

### **Linde/Lotepro Corporation**

Gordon W. Kumke  
Mt. Pleasant Corporate Center  
115 Stevens Avenue  
Valhalla, NY 10595  
Phone: 914/749-5204  
Fax: 914/747-3422

**Mason Dixon Farms, Inc.**

1800 Mason Dixon Road  
 Gettysburg, PA 17325  
 Phone: 717/334-4056  
 E-mail: mdf@cvn.net

**Microgy Cogeneration Systems, Inc.**

Benjamin Brant  
 1767A Denver West Blvd. Suite 15  
 Golden, CO 80401  
 Phone: 303/384-9402  
 Fax: 303/384-9403  
 Web site: www.microgy.com  
 E-mail: bbrant@microgy.com

**Northern Power Corporation**

Tyler Marks (in Madison, WI)  
 608-223-1035 x220

**BLOWERS****Aerzen USA Corporation**

645 Sands Court  
 Coatsville, PA 19320  
 Phone: 610/524-9870  
 E-mail: aerzenus@worldnet.att.net  
 Web site: www.aerzener.com

**EG&G Rotron**

Industrial Division  
 75 North Street  
 Saugerties, NY 12477  
 Phone: 914/246-3401  
 Web site: http://www.rotrontmd.com

**Gast Manufacturing**

P.O. Box 97

**BOILERS/WATER HEATERS****Applied Thermal Systems, Inc.**

P.O. Box 101493  
 Nashville, TN 37210  
 Phone: 615/366-0221  
 Fax: 615-366-0290

**Bryan Steam Corporation**

P.O. Box 27  
 Peru, IN 46970  
 Phone: 317/473-6651  
 Web site: http://www.bryanboilers.com

**Carolina Technical Representatives, Inc.**

P.O. Box 1115  
 Matthews, NC 28105  
 Phone: 704/847-4494

**Oswald Green, Inc.**

Dr. William J. Oswald, PE  
 1081 St. Francis Drive  
 Concord, CA 94518  
 Phone: 510/689-3727  
 Fax: 510/682-2093

**Resource Conservation Management, Inc.**

Mr. Mark Moser  
 P.O. Box 4715  
 Berkeley, CA 94704  
 Phone: 510/658-4466  
 Fax: 510/658-2729  
 E-mail: rcmdigesters@att.net  
 Web site:  
 www.rcmdigesters.com

Benton Harbor, MI 49023-0097

Phone: 616/926-6171  
 Fax: 616-927-0808  
 Web site:  
 http://www.gastmfg.com

**Jet-Pro Company, Inc.**

Mr. Garland Rice  
 President  
 11032 U.S. Hwy. 59  
 Atchinson, KS 66002  
 Phone: 913/367-3478

**Roots Div. Dresser Industries, Inc.**

900 W. Mount Street

**Cleaver Brooks**

P.O. Box 421  
 Milwaukee, WI 53201  
 Phone: 800/535-3275  
 Web site:  
 http://www.cleaverbrooks.com

**EnerCorp**

9369 Olive Blvd., Suite 201  
 St. Louis, MO 63132  
 Phone: 314/569-2884

**Entech Environmental Services, Inc.**

180 Hickory Flat Road  
 Canton, GA 30114  
 Phone: 800/218-8859  
 Fax: 770-720-1972

**Sharp Energy, Inc.**

Roy Sharp  
 20174 Road 140  
 Tulare, CA 93274  
 Phone: 559/688-2051  
 Fax: 559/688-1111  
 E-mail: rsharp6368@aol.co

Connersville, IN 47331

Phone: 317/827-9200  
 Fax: 765-827-9266

**Semblem**

1635 W. Walnut  
 Springfield, MO 65802  
 Phone: 417/866-1035

**Tectonic Construction Company**

Robert Lowdermilk  
 PO Box 385  
 Pinecliff, CO 80471  
 E-mail: boblowder@aol.com

**Industrial Boiler Co., Inc.**

221 Law Street  
 P.O. Dawer 2258  
 Thomasville, GA 31799  
 Phone: 912/226-3024

**Kewanee Mfg. Co., Inc.**

101 Franklin Street  
 Kewanee, IL 61443  
 Phone: 309/853-3541  
 Fax: 309-852-3953

**North American Manufacturing Co.**

4455 E. 71st Street  
 Cleveland, OH 44105-5600  
 Phone: 216/271-6000  
 Fax: 216-641-7852

**Precision Temp**

1100 Harrison Avenue  
Cincinnati, OH 45214  
Phone: 513/651-4446  
Fax: 513-641-0733  
Web site:  
<http://www.precisiontemp.com>

**ABSORPTION CHILLERS****American Yazaki Corporation**

13740 Omega Road  
Farmers Branch, TX 75244  
Phone: 214/385-8725  
Fax: 972-385-1324  
Web site:  
<http://www.yazakienergy.com>

**COGENERATION****Barnco International**

5410 Kennon Lane  
Bossier City, LA 71112  
Phone: 318/741-1073  
Fax: 318-741-1175  
Web site: <http://www.in-gen.com>

**Caterpillar Engine Co.**

Mr. Michael Reinhart  
Senior Application Consultant  
3701 State Road 26 East  
Lafayette, IN 47905  
Phone: 317/448-5946  
Fax: 317/448-5985  
E-mail:  
[michaeljreinhart/oh/caterpillar@caterpillar.com](mailto:michaeljreinhart/oh/caterpillar@caterpillar.com)

**Curtis Engine and Equipment, Inc.**

Mr. Richard Ay, Sr.  
Senior Vice President/General  
Manager  
3918 Vero Road, Suite L  
Baltimore, MD 21227-1516  
Phone: 800/573-9200  
Fax: 410/536-2098  
E-mail: [sales@curtisengine.com](mailto:sales@curtisengine.com)  
Web site:  
<http://www.curtisengine.com>

**Jenbacher Energiesysteme, Ltd.**

Mr. Karl W. Hartleb, President  
1502 Providence Highway  
Suite #2  
Norwood, MA 02062  
Phone: 617/255-5886  
Fax: 617/255-5887

**Technotherm Corporation**

5508 West 66th Street  
South Tulsa, OK 74131  
Phone: 918/446-1533  
Fax: 918-446-6051

**CECA, Inc. Absorption Technology**

4150 S. 100th East Avenue,  
Suite 300  
Tulsa, OK 74146  
Phone: 313/737-4591

**Kohler Co., Generator Div.**

444 Highland Drive  
Sheboygan, WI 53044  
Phone: 800/544-2444  
Web site:  
<http://www.kohlergenerators.com>

**Martin Machinery Inc.**

Mr. Harlan Martin  
123 Lakeview Road  
Latham, MO 65050  
Phone: 816/458-7000  
Fax: 816/458-7100  
E-mail:  
[marmachinerymo@characterlink.net](mailto:marmachinerymo@characterlink.net)

**Midwesco Energy Systems**

7720 Lehigh Avenue  
Niles, IL 60648  
Phone: 708-966-2150  
Fax: 847-966-6549  
Web site: [midwesco-services.com](http://midwesco-services.com)

**Natural Power, Inc.**

Ms. Cynthia Rowland  
Environmental R & D  
Manager  
3000 Greshams Lake Road  
Raleigh, NC 27615  
Phone: 919/876-6722  
Fax: 919/876-1877  
Web site:  
<http://www.natpowerinc.com>

**Virginia Technical Associates, Inc.**

7202 Impala Drive  
Richmond, VA 23228  
Phone: 804/266-9654

**Robur Corporation**

2300 Lynch Road  
Evansville, IN 47711-2908  
Phone: 812/424-1800  
Fax: 812-422-5117

**Perennial Energy, Inc.**

Ted Landers  
Route 1, Box 645  
West Plains, MO 65775  
Phone: 417/256-2002  
Fax: 417/256-2801

**Gregory Poole Power Systems**

Mr. Joseph Tripp  
Electric Power Generator Sales  
Manager  
701 Blue Ridge Road  
Raleigh, NC 27606  
Phone: 919/890-4310  
Fax: 919/890-4334

**Safe Environmental Inventions, Inc.**

Mark Thomas  
Suite 610  
1155 North State Street  
Bellingham, WA 98225  
Phone: 360/647-2800  
Fax: 360/647-5178

**The Stranded Gas Association, Inc.**

Mr. Dennis Cousino  
President  
205 S. Broadway  
Coweta, OK 74429  
Phone: 918/486-3085

**Tecogen**

P.O. Box 8995  
Waltham, MA 02254-8995  
Phone: 617/622-1400  
Fax: 781-622-1025  
Web site: <http://www.thermal.com>

**CONSULTING/TECHNICAL ASSISTANCE****AgPro, Inc.**

Mr. Joe Gribble  
President  
32854 South Dryland Road  
Molalla, OR 97038  
Phone: 503/829-4844

**Agri-Bio Systems, Inc.**

Mr. R.L. Vetter, President  
P.O. Box 5144  
Elgin, IL 60121  
Phone: 847/888-7854  
Fax: 847/888-1484  
E-mail: [rvagribio@aol.com](mailto:rvagribio@aol.com)

**AgriWaste Technology, Inc.**

Mr. Mac Safley  
3504 Sloan Court  
Raleigh, NC 27606  
Phone: 919/851-8528  
Fax: 919-829-1507  
E-mail: [agriwaste@aol.com](mailto:agriwaste@aol.com)

**Agricultural Engineering Associates**

Mr. John A. George  
President/Chief Engineer  
102 E. Second  
Uniontown, KS 66779  
Phone: 316/756-4845  
Fax: 316/756-4847  
Web site: [agengineering.com](http://agengineering.com)  
E-mail: [georgeaea@ckt.net](mailto:georgeaea@ckt.net)

**Brubaker Agronomic Consulting Service, Inc.**

Mr. Michael Brubaker  
President/CEO/Owner  
4340 Oregon Pike  
Ephrata, PA 17522  
Phone: 717/859-3276  
Fax: 717/859-3416  
Web site: <http://www.brubakerag.com>

**Waukesha Engine Division**

1000 West St. Paul Avenue  
Waukesha, WI 53188  
Phone: 414/547-3311  
Fax: 414-549-2989

**C & S Engineers, Inc.**

Mr. Tom Dussing  
Environmental Division  
Manager  
1099 Airport Blvd.  
North Syracuse, NY 13212  
Phone: 315/455-2000 ext 249  
Fax: 315/455-9667  
Web site:  
<http://www.cscos.com>

**Commercial Engineering Corporation - Anergen Division**

Ashok Bendre  
430 Lake Cook Road, Suite B  
Deerfield IL 60015  
Phone: 847/236-0900  
E-mail: [arbend@aol.co](mailto:arbend@aol.co)  
Web site:  
[www.anergencorp.co](http://www.anergencorp.co)

**Dubara Company**

Stephen Hoyt  
1177 Route 9  
Castleton NY 12033  
Phone: 518/732-7618  
Fax: 518/732-7618  
E-mail: [steveh@albany.net](mailto:steveh@albany.net)

**E3 Ventures**

Gary Suskauer  
1140 Kildaire Farm Road, Suite 304  
Cary NC 27511  
Phone: 919/469-3737  
Fax: 919/469-3656  
E-mail:  
[gsuskauer@e3ventures.com](mailto:gsuskauer@e3ventures.com)  
Web site:  
[www.e3ventures.com](http://www.e3ventures.com)

**Ecofuels Corp.**

Jeffrey Lighthouse  
1710 Douglas Drive North  
Golden Valley, MN 55422

Web site:  
<http://www.engine.com>

**Entech Environmental Systems, Inc.**

180 Hickory Flat Road  
Canton, GA 30114  
Phone: 800/218-8859  
Fax: 770-720-1972

**Enviroenergy Systems, Inc.**

Mr. Paul Serbu  
Vice President, Systems  
Development  
7860 Woodridge Drive  
Gainsville, VA 22065  
Phone: 703/754-2042  
Fax: 703/476-0414

**Environmental Treatment Systems, Inc.**

P.O. Box 94005  
Atlanta, GA 30377  
Phone: 770/384-0602  
Fax: 770-384-0603

**Environomics, Inc.**

Mr. Richard Mattocks  
36 West 35th Street  
Suite 5E  
New York, NY 10001  
Phone: 212/564-7188  
Fax: 718/884-6726  
E-mail:  
[utter@compuserve.com](mailto:utter@compuserve.com)  
Web site:  
<http://www.waste2profits.com/>

**GHD Inc.**

Steve Dvorak  
P.O. Box 69  
Chilton WI 53014  
Phone: 920/849-9797  
Fax: 920/849-9160  
E-mail: [ddghd@tds.net](mailto:ddghd@tds.net)



**IGT**

J. Robert Paterek, Ph.D  
 1700 S. Mount Prospect Road  
 Des Plaines IL 60016  
 Phone: 847/768-0720  
 Fax: 847/768-0546  
 E-mail: paterek@gastechnology.org  
 Web site:  
<http://www.gastechnology.org>

**IGT**

Laurence M. Feder  
 1700 S. Mount Prospect Road  
 Des Plaines IL 60016  
 Phone: 847/768-0521  
 Fax: 847/768-0516  
 E-mail:  
[lanny\\_feder@gastechnology.org](mailto:lanny_feder@gastechnology.org)  
 Web site:  
<http://www.gastechnology.org>

**National Methane**

William J. Lingo, Sr.  
 905 Glendean Ave., Suite 8  
 Riverside OH 45431  
 Phone: 937/256-750  
 Fax: 937/256-750  
 E-mail: [bilingo@dma.org](mailto:bilingo@dma.org)

**Nelson and Associates**

D.O. "Swede" Nelson  
 76 Almendral Ave.  
 Atherton CA 94027  
 Phone: 650/364-7273  
 Fax: 650/367-0365  
 E-mail: [swedenelson@msn.com](mailto:swedenelson@msn.com)

**Perennial Energy, Inc.**

Mr. Ted Landers  
 Route 1, Box 645  
 West Plains, MO 65775  
 Phone: 417/256-2002  
 Fax: 417-256-2801

**Resource Conservation Management, Inc.**

Mr. Mark Moser  
 P.O. Box 4715  
 Berkeley, CA 94704  
 Phone: 510/658-4466  
 Fax: 510/658-2729  
 E-mail: [rcmdigesters@att.net](mailto:rcmdigesters@att.net)  
 Web site:  
[www.rcmdigesters.com](http://www.rcmdigesters.com)

**Richard Chambers**

Richard Chambers  
 1102 Don Cubero Ave  
 Santa Fe NM 87501  
 E-mail: [Rhcha@aol.com](mailto:Rhcha@aol.com) 1

**Richmond Energy Associates**

Jeff Forward  
 P.O. Box 615  
 Richmond VA 05477  
 Phone: 802/434-3770  
 Fax: 802/434-2344  
 E-mail: [forward@together.net](mailto:forward@together.net)

**Taylor & Thomas Environmental, Inc.**

Dennis Crabtree, Pres.  
 2669 Cristal Circle  
 Dunedin, FL 34698  
 Phone: 727-781-5846  
 Fax: 727-781-5759

**VerdiTech**

Ken Abercrombie  
 12749 East Heather Dr  
 Clovis CA 93611  
 Phone: 559/297-7370  
 Fax: 559/297-7370  
 E-mail: [verditch@aol.com](mailto:verditch@aol.com)

**ENGINES****CEC Consultants**

John Puskar  
 6907 Brookpark Rd.  
 Cleveland OH 44129  
 Phone: 216/749-2992  
 Fax: 216/398-8403  
 E-mail: [cec@apk.net](mailto:cec@apk.net)  
 Web site: [www.cec-consultants.com](http://www.cec-consultants.com)

**Reflective Energies**

Edan Prabhu  
 22922 Tiagua  
 Mission Viejo CA 92692  
 Phone: 949/380-4899  
 Fax: 949/380-8407  
 E-mail: [edanprabhu@msn.co](mailto:edanprabhu@msn.co)

**STM Corporation**

(mfg. Stirling engines)  
 275 Metty Drive  
 Ann Arbor, MI 48103  
 Phone: 734/995-1755  
 E-mail: [LenSTM@aol.com](mailto:LenSTM@aol.com)

**FLARES/THERMAL OXIDIZERS****Flaregas Corporation**

100 Airport Executive Park  
 Spring Valley, NY 10977  
 Phone: 914/352-8700  
 Fax: 914-352-4464

**Groth Equipment Corporation**

P.O. Box 15293  
 Houston, TX 77220-5293  
 Phone: 713/675-6151  
 Fax: 713-675-7639  
 E-mail: [sales@grothcorp.com](mailto:sales@grothcorp.com)  
 Web site:  
<http://www.grothcorp.com>

**John Zink Co.**

P.O. Box 21220  
 Tulsa, OK 74121-1220  
 Phone: 918/234-1800  
 Fax: 918-234-2700  
 Web site:  
<http://www.kochind.com>

**Landfill Technologies, Inc.**

Mr. George Nealon  
P.O. Box 519  
West Sand Lake, NY 12196  
Phone: 518/674-8604

**LFG Specialties, Inc.**

725 South Friendship Drive  
New Concord, OH 43762  
Phone: 614/826-7686  
Fax: 614/826-4948  
Web site:  
<http://www.mail@lfgspecialties.com>

**McNeil Technologies, Inc.**

Mr. Scott Haase  
350 Indiana Street, Ste. 800  
Golden, CO 80401  
Phone: 303/273-0071  
Fax: 303/273-0074

**NAO, Inc.**

1284 East Sadgley Avenue  
Philadelphia, PA 19134  
Phone: 800/523-3495  
Fax: 215-743-3018

**Perennial Energy, Inc.**

Route 1, Box 645  
West Plains, MO 65775  
Phone: 417/256-2002  
Fax: 417-256-2801

**Tornado Flare Systems, Inc.**

10543B W. Little York  
Houston, TX 77041  
Phone: 409/732-5546  
Fax: 409-732-2393  
Web site: [tornadoflare.com](http://tornadoflare.com)

**Whitehorse Technologies, Inc.**

3211 Shannon Street  
Santa Ana, CA 92704  
Phone: 714/438-9270  
Fax: 714-438-9275

**FLOATING COVERS****AmbiaTech, Inc.**

*Aeroblanket*  
James W. Barnett, Jr., PhD  
6505 Alasan Cove  
Austin, Texas 78730  
Web site:  
<http://www.nppc.org/PROD/OSI/cavanaugh/summaries.html>

**Best Incorporated**

Mr. David Barnes  
President  
1108 Nowell Road  
Raleigh, NC 27607  
Phone: 919/851-3009  
Fax: 919/851-1224

**Baumgartner Environics**

*BioCap technology*  
2510 West Lincoln, Suite 4 Olivia, MN  
56277  
Phone: (320) 523-1644  
E-mail: [biocap@bei-ec.com](mailto:biocap@bei-ec.com)  
Web site: <http://www.bei-ec.com/>

**Burke Environmental Products**

2250 S. Tenth Street  
San Jose, CA 95112  
Phone: 408/297-3500  
Fax: 408-820-0938

**Cooley Engineered Membranes, Inc.**

P.O. Box 939  
Pawtucket, RI 02862  
Phone: 800/444-4023  
Fax: 401-725-4190

**Engineered Textile Products, Inc.**

Mr. Carter Damp  
P.O. Box 7474  
Mobile, AL 36670  
Phone: 334/476-8001  
Fax: 334/476-0956  
E-mail: [cdamp2@aol.com](mailto:cdamp2@aol.com)  
Web site: [www.etpinfo.com](http://www.etpinfo.com)

**Environetics, Inc.**

1200 Commerce Street  
Lockport, IL 60441  
Phone: 815/838-8331  
Fax: 815-838-8336  
E-mail: [envnet@aol.com](mailto:envnet@aol.com)

**Environmental Fabrics, Inc.**

Mr. Dennis Shanklin  
President  
2014 Rockland Road  
Columbia, SC 29210  
Phone: 803/551-5700  
Fax: 803/551-5701

**GeoPacific Lining**

Mr. Douglas Nickson  
National Sales Manager  
1300 Dexter Avenue North,  
Suite 205  
Seattle, WA 98109  
Phone: 206/284-2378  
Fax: 206/283-7068  
E-mail:  
[geopacific@cresmont.co](mailto:geopacific@cresmont.co)

**GSE Lining Technology, Inc.**

(formerly Gundle Lining)  
19103 Gundle Road  
Houston, TX 77073  
Phone: 713/443-8564  
Fax: 281-875-6010

**Industrial & Environmental Concepts, Inc.**

6009 Chapel Drive  
Suite 101  
Minneapolis, MN 55439  
Phone: 612/829-0731  
Fax: 612-829-9770  
Web site:  
<http://www.ieccovers.com>

**LBi Technologies, Inc.**

Mr. Jordan Colburn  
Factory Representative  
31 Corte Ortega #24  
Greenbrae, CA 94904  
Phone: 415/925-0226  
Fax: 415/461-0306

**Lemna USA, Inc.**

1408 Northland Drive, Suite  
310  
St. Paul, MN 55120-1013  
Phone: 612/688-0836  
Fax: 612/688-8813

**Poly-Flex, Inc.**

2000 W. Marshall Drive  
 Grand Prairie, TX 75051  
 Phone: 888/765-9359, ext.7269  
 Fax: 972/337-8269

**Unit Liner Company**

Mr. Alan Buck  
 President  
 7801 N. Kickapoo  
 Shawnee, OK 74801  
 Phone: 800/633-4603  
 Fax: 405/275-4625  
 E-mail: liner@oklahoma.net  
 Web site: <http://www.unitliner.com>

**United Foam Plastics Corp.**

172 East Main Street  
 Georgetown, MA 01833  
 Phone: 617/352-2200

**Reef Industries**

Lynn Ciolli  
 Sales  
 P.O. Box 750250  
 Houston, TX 77275-0250  
 Phone: 713/507-4200  
 Fax: 713/507-4295  
 E-mail: ri@reefindustries.com  
 Web  
 site:<http://www.reefindustries.com>

**Seaman Corporation**

Industrial Fabric Division  
 1000 Ventura Blvd.  
 Wooster, OH 44691  
 Phone: 800/927-8578  
 Fax: 330-263-6950  
 Web site:  
<http://www.seamancorp.com>

**Sharp Energy, Inc.**

Roy Sharp  
 24684 Road 148  
 Tulare CA 93274  
 Phone: 559/688-2051  
 Fax: 559/688-1111  
 E-mail: rsharp6368@aol.co

**GAS HANDLING****Impco**

Department ASE  
 16916 Gridley Place  
 Cerritos, CA 90701

**Perennial Energy, Inc.**

Route 1, Box 645  
 West Plains, MO 65775  
 Phone: 417/256-2002  
 Fax: 417-256-2801

**Protectseal Co.**

225 Foster Avenue  
 Bensenville, IL 60106  
 Phone: 708/595-0800  
 Fax: 630-595-8059  
 E-mail: info@protectoseal.com  
 Web site:  
<http://www.protectoseal.com>

**Whessoe Varec**

Mr. Richard Santucci  
 Biogas Business Unit Manager  
 10800 Valley View Street  
 Cypress, CA 90630  
 Phone: 714/761-1300  
 Fax: 714/952-2701  
 Web site:  
<http://www.whessoevarec.com>

**GAS METERS****American Meter Co.**

13500 Philmont Avenue  
 Philadelphia, PA 19116  
 Phone: 215/673-2100  
 Fax: 215-830-1890  
 Web site:  
<http://www.americanmeter.com>

**Fluid Components International**

1755 La Costa Meadows Drive  
 San Marcos, CA 92069-5187  
 Phone: 619/744-6950  
 Fax: 760-736-6250  
 E-mail:  
[sales\\_marketing@fluidcomponents.com](mailto:sales_marketing@fluidcomponents.com)

Web site:  
<http://www.fluidcomponents.com>

**Kurz Instruments, Inc.**

2411 Garden Road  
 Monterey, CA 93940  
 Phone: 800/424-7356

**HEATERS/HEAT EXCHANGERS****Modine Manufacturing Co.**

1500 DeKoven Avenue  
 Racine, WI 53403-2552  
 Phone: 414/636-1200  
 Fax: 414-636-1424

**Mueller Co.**

P.O. Box 828  
 Springfield, MO 65801-0828  
 Phone: 417/831-3000  
 Fax: 417-831-3528  
 E-mail: sales@muel.com  
 Web site:  
<http://www.paulmueller.com>

**W. A. Kraft Corporation**

45 Sixth Road  
 Woburn, MA 01888  
 Phone: 617/938-9100  
 Fax: 781-933-7812

## INSTRUMENTATION

### **Bacharach, Inc.**

625 Alpha Drive  
Pittsburgh, PA 15238  
Phone: 800/736-4666  
Fax: 412-963-2091

### **Dresser Measurement, Dresser Industries**

P.O. Box 42176  
Houston, TX 77242-2176  
Phone: 713/972-5000  
Fax: 713-972-5003  
Web site: <http://www.halliburton.com>

### **Dwyer Instruments, Inc.**

P.O. Box 373  
Michigan City, IN 46360  
Phone: 219/879-8000  
Fax: 219-872-9057  
E-mail: [info@dwyer-inst.com](mailto:info@dwyer-inst.com)  
Web site: <http://www.dwyer-inst.com>

### **ENMET Corporation**

P.O. Box 979  
Ann Arbor, MI 48106  
Phone: 313/761-1270  
Fax: 734-761-3220  
E-mail: [info@enment.com](mailto:info@enment.com)  
Web site:  
<http://www.enmet.com>

### **Fischer & Porter Co.**

125 E. Country Line Road  
Warminster, PA 18974  
Phone: 215/674-6000  
Fax: 215-674-7181  
Web site: <http://www.fp.com>

### **Matheson Gas Products, Inc.**

30 Seaview Drive  
P.O. Box 1587  
Secaucus, NJ 07096-1587  
201-867-4100  
Fax: 201-933-1928  
Web site:  
<http://www.mathesongas.com>

### **U.S. Industrial Products Co., Inc.**

13926 Equitable Road  
Cerritos, CA 90703  
Phone: 562/802-9688

## OTHER

### **AmeriScan Technologies Corp.**

Mr. Robert F. Urell  
President  
8545 Kapp Drive  
Peosta, IA 52068  
Phone: 319/582-9856  
*Equipment/Systems Vendor*

### **Applied Technologies, Inc.**

Mr. John F. Kouba, P.E.  
Senior Project Manager  
16815 West Wisconsin Avenue  
Brookfield, WI 53005  
Phone: 414/784-7690  
Fax: 414/784-6847  
E-mail: [jfkouba@ati-ae.co](mailto:jfkouba@ati-ae.co)

### **Bearden, Beaty & Associates, Inc.**

Mr. Robert Reid  
Engineering Manager  
707 Whilcock Avenue  
Building H-11  
Marietta, GA 30064  
Phone: 770/952-3778  
Fax: 770/952-4778  
*Engineering and technical support to the power industry.*

### **Biogas Industries, Inc.**

Mr. Larry Foster  
President  
P.O. Box 278  
Moody, TX 76557  
Phone: 817/853-3904  
Fax: 817/853-3823  
*"Methane promoter"*

### **Biogas Works--Resource Development Associates**

240 Ninth Street, NE  
Washington DC 20002-6110  
Philip Lusk  
Phone: 202.546.6283  
Fax: 202.546.3518  
E-Mail: [plusk@pipeline.com](mailto:plusk@pipeline.com)  
Web site  
[www.biogasworks.com](http://www.biogasworks.com)

### **Commonwealth ResourceManagement Corp.**

Mr. Anton Finelli  
199 Corey Street  
Boston, MA 02132

### **Convergent Biomass Technologies**

Mr. Mark Heffernan  
President  
1725 N. Woods Street  
Suite NW  
Round Lake Beach, IL 60073  
*2 phase digester licensee*

### **Crane Engineering Sales Inc.**

PO Box 38 707 Ford Street  
Kimberly WI 54136-0038  
Michael Ruge  
Phone: 920-733-4425  
Fax: 920-733-0050  
E-Mail: [mikerug@crane-eng.com](mailto:mikerug@crane-eng.com)  
Website <http://www.crane-eng.com>  
*Process equipment design and equipment supply, including piping, metering, filters, mixers, valves, and design of piping*

**Creative Land Management International**

Mr. Rob Lintz  
6450 Sand Lake Road  
Dayton, OH 45413  
Phone: 937/427-5560  
Fax: 937/454-2919  
*International building materials and resource recovery projects.*

**CropKing Inc.**

5050 Greenwich Road  
Seville, OH 44273  
Phone: 330/769-2002  
Fax: 330/769-2616  
Web site: <http://www.cropking.com>  
*Hydroponics/Greenhouses*

**D.J.F. Electrical Systems**

Mr. Douglas Fink, Owner  
PO Box 544  
Harrisburg, NC 28075  
Phone: 704-597-5018  
E-mail: [dugit2@aol.com](mailto:dugit2@aol.com)  
*Electrical contractor*

**Evergreen Bioservices**

Mr. David Sergnier  
RR 7, Box 488  
Ada, OK 74820  
Phone: 405/332-3110  
Fax: 405-222-0898  
E-mail: [surgnier@cwix.com](mailto:surgnier@cwix.com)  
*Bioremediation company*

**Farm Research & Development Corp.**

Mr. Andrew T. Barrett  
Sales Executive  
13915 I Avenue  
Fayette, IA 52142

**George Brothers**

Mr. James George  
President  
P.O. Box 232  
Okauchee, WI 53069  
Phone: 414/569-1758  
Fax: 414/569-1828  
*Reclamation of energy, feed content and by-products from organic waste streams*

**Gothic Arch Greenhouses**

Mr. W.H. Sierke, Jr.  
President/CEO  
P.O. Box 1564  
Mobile, AL 36633-1564  
Phone: 334/432-7529  
Fax: 334-432-7972  
Web site:  
<http://www.zebra.net/~gothic>  
*Greenhouse design for alternative energy uses*

**Grow Moore Products**

Mr. Del Gurley  
Production Manager  
6 Shadowood Drive  
Conroe, TX 77304  
Phone: 409/441-1676  
*Environmental consulting/Organics production and Manufacturing*

**IES, Inc.**

Mr. Richard Ransom  
President  
1222 W. Shaw Avenue  
Fresno, CA 93711  
Phone: 209/226-6611  
Fax: 209/225-6762  
*Anaerobic digestion/cogeneration.*

**IoNova**

Mr. David Tepperman  
Vice President, Sales  
Jack O. Payne  
COO, Vice President,  
Engineering, R&D  
171 N. Van Ness Avenue  
Fresno, CA 93701  
Phone: 209/233-7252 (Sales)  
Phone: 209/642-6467  
(Engineering)  
Fax: 209/233-9126  
*Own, operate and maintain biomechanical systems for fair share of savings. Remote monitor and control, client furnishes only space.*

**J.E. Gasho & Associates**

Mr. James Gasho, President  
460 W. Gay Street  
West Chester, PA 19380  
Phone: 610/692-5650  
Fax: 610/692-5857  
*Factory representatives for air moving equipment.*

**Marquette University, Air Quality Center**

Civil & Env. Engineering, PO  
Box 1881  
Milwaukee WI 53201-1881  
Daniel Zitomer  
Phone: 414-288-5733  
Fax: 414-288-7521  
E-Mail:  
[daniel.zitomer@marquette.edu](mailto:daniel.zitomer@marquette.edu)  
Web site  
<http://www.eng.mu.edu/departments/ceen/environmental.html>  
*Anaerobic treatability studies, enhanced gas production, improved settleability, and Wisconsin certified laboratory testing*

**Michigan State University**

Keith Tinsey  
Dept. of Agricultural  
Engineering  
Directory of the MI Agricultural  
Electric Council  
103C Farrall Hall  
East Lansing, MI 48824  
Phone: 517/353-0643  
E-mail: [tinsey@msu.edu](mailto:tinsey@msu.edu)

**Omega-Alpha Recycling Systems**

Mr. Robert Hamburg  
Director  
Route 1, Box 51  
Orma, WY 25268  
Phone: 304/655-8662  
E-mail:  
[anomalous@wvadventures.net](mailto:anomalous@wvadventures.net)  
*Research and development of integrated organic production recycling systems.*

**Robert E. Lee & Associates**

2825 S. Webster St.  
Green Bay WI 54306  
Richard Swiontak  
Phone: 920-336-6338 Fax: 920-336-9141  
E-Mail: r.swiontek@releeinc.com  
Web site www.releeinc.com  
*A full-service consulting firm specializing in civil and environmental engineering, planning, surveying and comprehensive laboratory testing.*

**Rutan Research**

P.O. Box 3766  
Minneapolis MN 55403-0766  
Al Rutan  
Phone: 612-870-7461  
Fax:  
E-Mail: arutan@commonlink.net  
Web site  
www.commonlink.com/~methane/  
*Thirty years international and domestic design and development of methane gas-producing equipment.*

**SWS Incorporated**

Mr. Richard Gray  
1148 Soria Avenue  
Orlando, FL 32807  
Phone: 407/382-0250  
Fax: 407/382-0250  
*System for generating methane gas from manure handling systems. Scientific Well Stimulation (SWS)*

**Universal Entech**

Mr. Daniel A. Musgrove  
Vice President and Project Manager  
12235 N. Cave Creek Road  
#6360  
Phoenix, AZ 85022  
Phone: 602/971-4869  
Fax: 602/971-4803  
*Integrated waste management.*

**UW Madison**

115 Agricultural Engineering  
Bldg 460 Henry Hall  
Madison WI 53706  
Jim Converse  
Phone: 608-262-1106  
Fax:  
E-Mail:  
jcconver@facstaff.wisc.edu

**TANKS****A.O. Smith Engineered Storage Products Company**

Rick Jones, Sales  
345 Harvestore Drive  
DeKalb, IL 60115  
Phone: 815-756-1551  
Fax: 815-756-1659  
Web site:  
http://www.aosmith.com/ OR  
www.slurrystore.com  
E-mail:  
rljones@esp.aosmith.com

